

HARDWARE DESCRIPTION

This chapter provides a detailed description of the 80C51 microcontroller (see Figure 1). Included in this description are:

- The port drivers and how they function both as ports and, for Ports 0 and 2, in bus operations
- The Timers/Counters

- The Serial Interface
- The Interrupt System
- Reset
- The Reduced Power Modes in CMOS devices
- The EPROM version of the 80C51

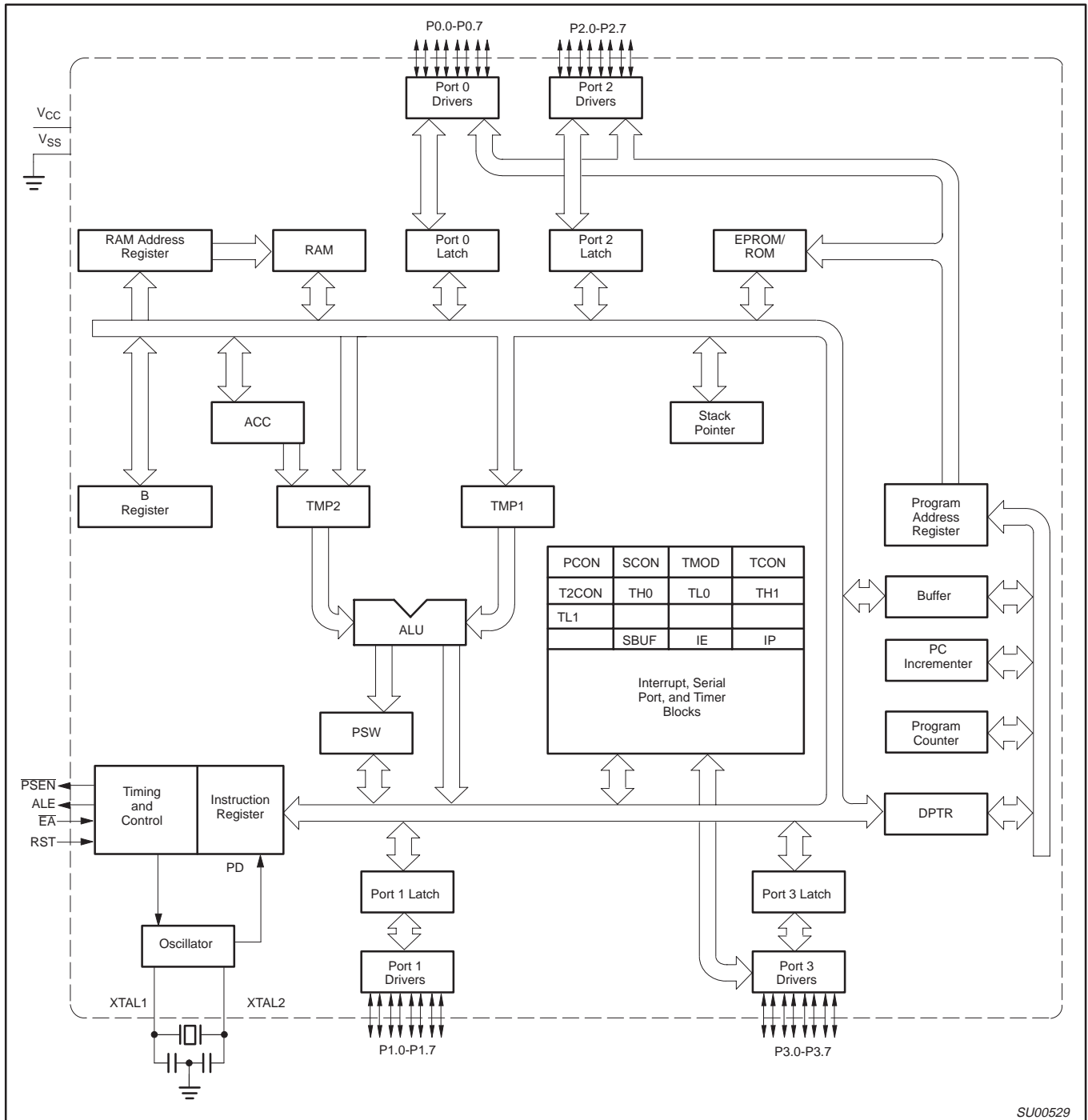

Figure 1. 80C51 Architecture

Special Function Registers

A Map of the on-chip memory area called the Special Function Register (SFR) space is shown in Figure 2.

Note that in the SFRs not all of the addresses are occupied. Unoccupied addresses are not implemented on the chip. Read accesses to these addresses will in general return random data, and write accesses will have no effect.

User software should not write 1s to these unimplemented locations, since they may be used in other 80C51 Family derivative products to invoke new features. The functions of the SFRs are described in the text that follows.

Accumulator

ACC is the Accumulator register. The mnemonics for Accumulator-Specific instructions, however, refer to the Accumulator simply as A.

B Register

The B register is used during multiply and divide operations. For other instructions it can be treated as another scratch pad register.

Program Status Word

The PSW register contains program status information as detailed in Figure 3.

Stack Pointer

The Stack Pointer register is 8 bits wide. It is incremented before data is stored during PUSH and CALL executions. While the stack may reside anywhere in on-chip RAM, the Stack Pointer is initialized to 07H after a reset. This causes the stack to begin at locations 08H.

Data Pointer

The Data Pointer (DPTR) consists of a high byte (DPH) and a low byte (DPL). Its intended function is to hold a 16-bit address. It may be manipulated as a 16-bit register or as two independent 8-bit registers.

Ports 0 to 3

P0, P1, P2, and P3 are the SFR latches of Ports 0, 1, 2, and 3, respectively. Writing a one to a bit of a port SFR (P0, P1, P2, or P3) causes the corresponding port output pin to switch high. Writing a zero causes the port output pin to switch low. When used as an input, the external state of a port pin will be held in the port SFR (i.e., if the external state of a pin is low, the corresponding port SFR bit will contain a 0; if it is high, the bit will contain a 1).

Serial Data Buffer

The Serial Buffer is actually two separate registers, a transmit buffer and a receive buffer. When data is moved to SBUF, it goes to the transmit buffer and is held for serial transmission. (Moving a byte to SBUF is what initiates the transmission.) When data is moved from SBUF, it comes from the receive buffer.

Timer Registers Basic to 80C51

Register pairs (TH0, TL0), and (TH1, TL1) are the 16-bit Counting registers for Timer/Counters 0 and 1, respectively.

Control Register for the 80C51

Special Function Registers IP, IE, TMOD, TCON, SCON, and PCON contain control and status bits for the interrupt system, the Timer/Counters, and the serial port. They are described in later sections.

Port Structures and Operation

All four ports in the 80C51 are bidirectional. Each consists of a latch (Special Function Registers P0 through P3), an output driver, and an input buffer.

The output drivers of Ports 0 and 2, and the input buffers of Port 0, are used in accesses to external memory. In this application, Port 0 outputs the low byte of the external memory address, time-multiplexed with the byte being written or read.

Port 2 outputs the high byte of the external memory address when the address is 16 bits wide. Otherwise, the Port 2 pins continue to emit the P2 SFR content.

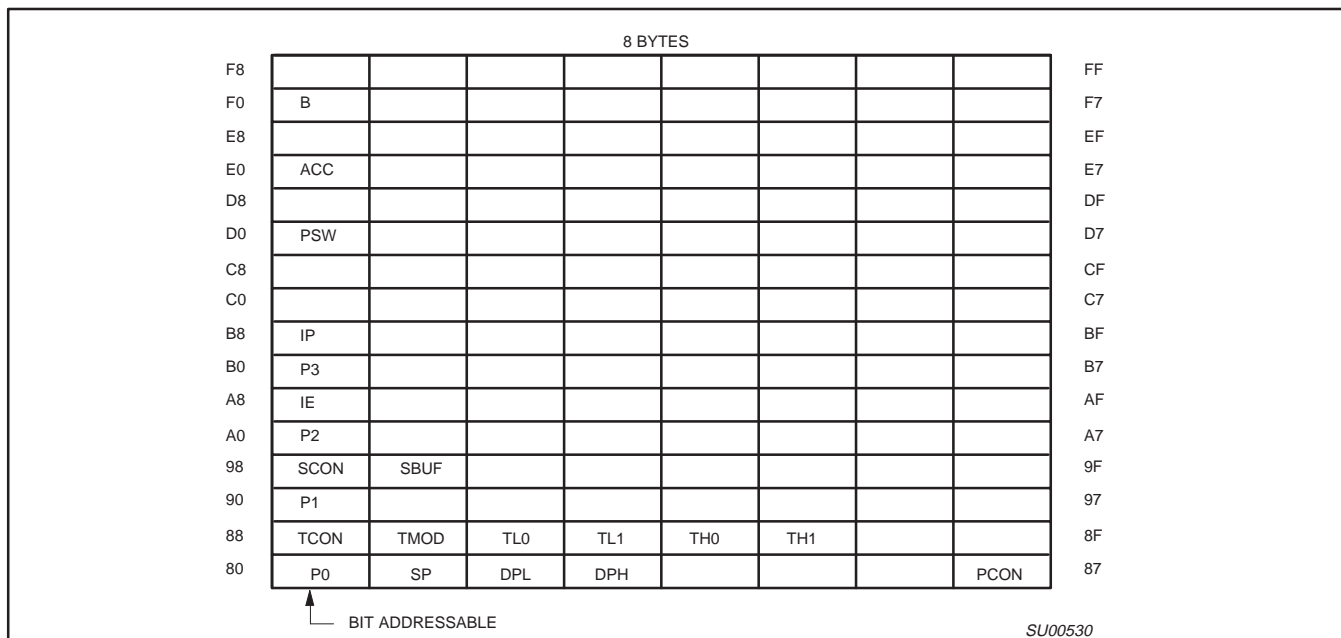

Figure 2. 80C51 SFR Memory Map

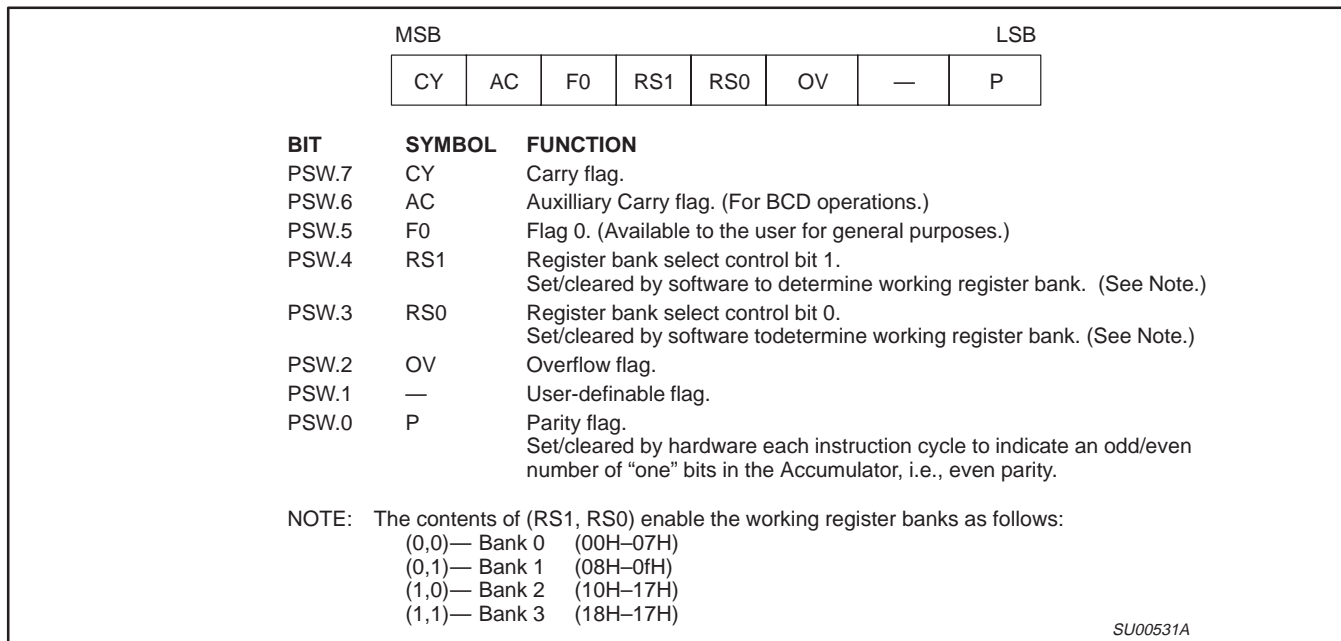

Figure 3. Program Status Word (PSW) Register

All the Port 3 pins are multifunctional. They are not only port pins, but also serve the functions of various special features as listed below:

Port Pin	Alternate Function
P3.0	RxD (serial input port)
P3.1	TxD (serial output port)
P3.2	$\overline{\text{INT0}}$ (external interrupt)
P3.3	$\overline{\text{INT1}}$ (external interrupt)
P3.4	T0 (Timer/Counter 0 external input)
P3.5	T1 (Timer/Counter 1 external input)
P3.6	$\overline{\text{WR}}$ (external Data Memory write strobe)
P3.7	$\overline{\text{RD}}$ (external Data Memory read strobe)

The alternate functions can only be activated if the corresponding bit latch in the port SFR contains a 1. Otherwise the port pin remains at 0.

I/O Configurations

Figure 4 shows a functional diagram of a typical bit latch and I/O buffer in each of the four ports. The bit latch (one bit in the port's SFR) is represented as a Type D flip-flop, which will clock in a value from the internal bus in response to a "write to latch" signal from the CPU. The level of the port pin itself is placed on the internal bus in response to a "read pin" signal from the CPU. Some instructions that read a port activate the "read latch" signal, and others activate the "read pin" signal.

As shown in Figure 4, the output drivers of Port 0 and 2 are switchable to an internal ADDR and ADDR/DATA bus by an internal CONTROL signal for use in external memory accesses. During external memory accesses, the P2 SFR remains unchanged, but the P0 SFR gets 1s written to it.

Also shown in Figure 4 is that if a P3 bit latch contains a 1, then the output level is controlled by the signal labeled "alternate output function." The actual P3.X pin level is always available to the pin's alternate input function, if any.

Ports 1, 2, and 3 have internal pullups, and Port 0 has open drain outputs. Each I/O line can be independently used as an input or an output. (Port 0 and 2 may not be used as general purpose I/O when

being used as the ADDR/DATA BUS for external memory during normal operation.) To be used as an input, the port bit latch must contain a 1, which turns off the output driver FET. Then, for Ports 1, 2, and 3, the pin is pulled high by a weak internal pullup, and can be pulled low by an external source.

Port 0 differs in that its internal pullups are not active during normal port operation. The pullup FET in the P0 output driver (see Figure 4) is used only when the port is emitting 1s during external memory accesses. Otherwise the pullup FET is off. Consequently P0 lines that are being used as output port lines are open drain. Writing a 1 to the bit latch leaves both output FETs off, so the pin floats. In that condition it can be used as a high-impedance input.

Because Ports 1, 2, and 3 have fixed internal pullups, they are sometimes called "quasi-bidirectional" ports. When configured as inputs they pull high and will source current (I_{IL} , in the data sheets) when externally pulled low. Port 0, on the other hand, is considered "true" bidirectional, because when configured as an input it floats.

All the port latches in the 80C51 have 1s written to them by the reset function. If a 0 is subsequently written to a port latch, it can be reconfigured as an input by writing a 1 to it.

Writing to a Port

In the execution of an instruction that changes the value in a port latch, the new value arrives at the latch during S6P2 of the final cycle of the instruction. However, port latches are in fact sampled by their output buffers only during Phase 1 of an clock period. (During Phase 2 the output buffer holds the value it saw during the previous Phase 1). Consequently, the new value in the port latch won't actually appear at the output pin until the next Phase 1, which will be at S1P1 of the next machine cycle.

If the change requires a 0-to-1 transition in Port 1, 2, or 3, an additional pullup is turned on during S1P1 and S1P2 of the cycle in which the transition occurs. This is done to increase the transition speed. The extra pullup can source about 100 times the current that the normal pullup can. It should be noted that the internal pullups are field-effect transistors, not linear resistors. The pullup arrangements are shown in Figure 5.

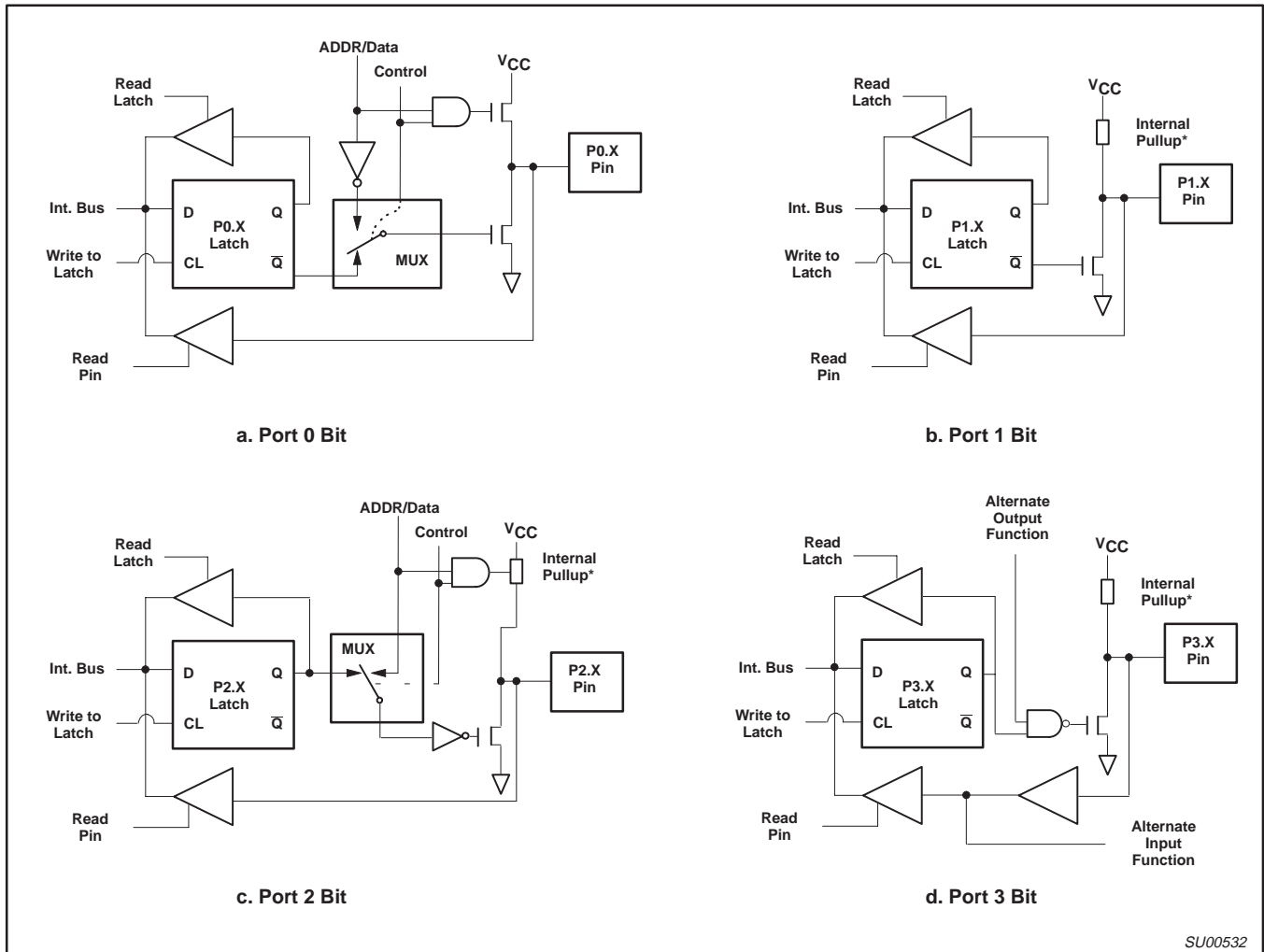

SU00532

*See Figure 5 for details of the internal pullup.

Figure 4. 80C51 Port Bit Latches and I/O Buffers

In the NMOS 8051 part, the fixed part of the pullup is a depletion mode transistor with the gate wired to the source. This transistor will allow the pin to source about 0.25mA when shorted to ground. In parallel with the fixed pullup is an enhancement mode transistor, which is activated during S1 whenever the port bit does a 0-to-1 transition. During this interval, if the port pin is shorted to ground, this extra transistor will allow the pin to source an additional 30mA.

In the CMOS 80C51, the pullup consists of three pFETs. It should be noted that an n-channel FET (nFET) is turned on when a logical 1 is applied to its gate, and is turned off when a logical 0 is applied to its gate. A p-channel FET (pFET) is the opposite: it is on when its gate sees a 0, and off when its gate sees a 1.

pFET1 in Figure 5 is the transistor that is turned on for 2 oscillator periods after a 0-to-1 transition in the port latch. While it's on, it turns on pFET3 (a weak pullup), through the inverter. This inverter and pFET3 form a latch which holds the 1.

Note that if the pin is emitting a 1, a negative glitch on the pin from some external source can turn off pFET3, causing the pin to go into

a float state. pFET2 is a very weak pullup which is on whenever the nFET is off, in traditional CMOS style. It's only about 1/10 the strength of pFET1. Its function is to restore a 1 to the pin in the event the pin had a 1 and lost it to a glitch.

Port Loading and Interfacing

The output buffers of Ports 1, 2, and 3 can each drive 4 LS TTL inputs. These ports on NMOS versions can be driven in a normal manner by a TTL or NMOS circuit. Both NMOS and CMOS pins can be driven by open-collector and open-drain outputs, but note that 0-to-1 transitions will not be fast.

In the NMOS device, if the pin is driven by an open-collector output, a 0-to-1 transition will have to be driven by the relatively weak depletion mode FET in Figure 5a. In the CMOS device, an input 0 turns off pullup pFET3, leaving only the very weak pullup pFET2 to drive the transition.

Port 0 output buffers can each drive 8 LS TTL inputs. They do, however, require external pullups to drive NMOS inputs, except when being used as the ADDRESS/DATA bus for external memory.

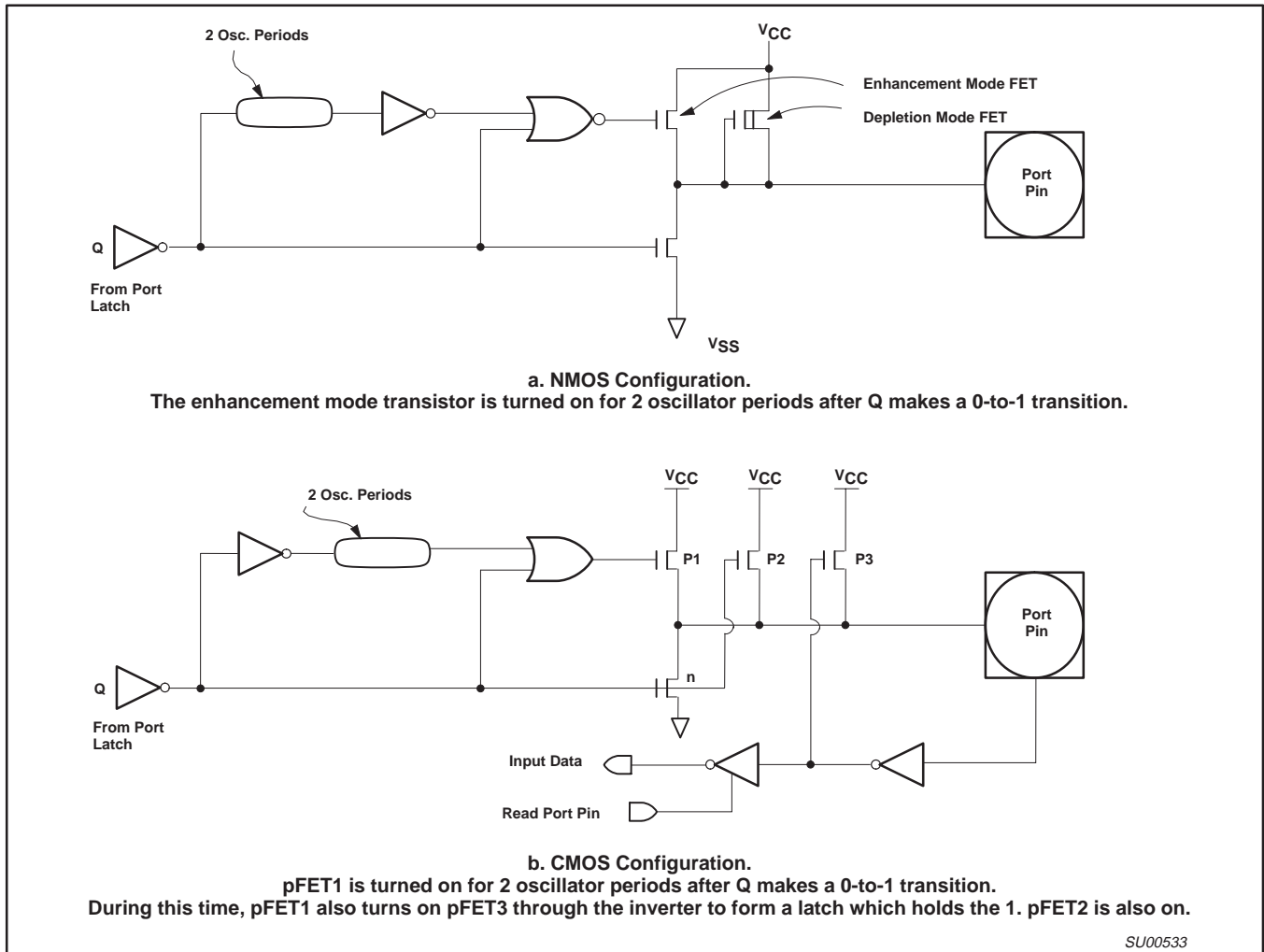

Figure 5. Ports 1 and 3 NMOS and CMOS Internal Pullup Configurations

(Port 2 is similar except that it holds the strong pullup on while emitting 1s that are address bits. See *Accessing External Memory*.)

Read-Modify-Write Feature

Some instructions that read a port read the latch and others read the pin. Which ones do which? The instructions that read the latch rather than the pin are the ones that read a value, possibly change it, and then rewrite it to the latch. These are called “read-modify-write” instructions. The instructions listed below are read-modify-write instructions. When the destination operand is a port, or a port bit, these instructions read the latch rather than the pin:

- ANL (logical AND, e.g., ANL P1,A)
- ORL (logical OR, e.g., ORL P2,A)
- XRL (logical EX-OR, e.g., XRL P3,A)
- JBC (jump if bit = 1 and clear bit, e.g., JBC P1.1,LABEL)
- CPL (complement bit, e.g., CPL P3.0)
- INC (increment, e.g., INC P2)
- DEC (decrement, e.g., DEC P2)
- DJNZ (decrement and jump if not zero, e.g., DJNZ P3,LABEL)
- MOV PX,Y,C (move carry bit to bit Y of Port X)
- CLR PX.Y (clear bit Y of Port X)
- SET PX.Y (set bit Y of Port X)

It is not obvious that the last three instructions in this list are read-modify-write instructions, but they are. They read the port byte, all 8 bits, modify the addressed bit, then write the new byte back to the latch.

The reason that read-modify-write instructions are directed to the latch rather than the pin is to avoid a possible misinterpretation of the voltage level at the pin. For example, a port bit might be used to drive the base of a transistor. When a 1 is written to the bit, the transistor is turned on. If the CPU then reads the same port bit at the pin rather than the latch, it will read the base voltage of the transistor and interpret it as a 0. Reading the latch rather than the pin will return the correct value of 1.

Accessing External Memory

Accesses to external memory are of two types: accesses to external Program Memory and accesses to external Data Memory. Accesses to external Program Memory use signal \overline{PSEN} (program store enable) as the read strobe. Accesses to external Data Memory use \overline{RD} or \overline{WR} (alternate functions of P3.7 and P3.6) to strobe the memory. Fetches from external Program Memory always use a 16-bit address. Accesses to external Data Memory can use either a 16-bit address (MOVX @ DPTR) or an 8-bit address (MOVX @Ri).

Whenever a 16-bit address is used, the high byte of the address comes out on Port 2, where it is held for the duration of the read or write cycle. Note that the Port 2 drivers use the strong pullups during the entire time that they are emitting address bits that are 1s. This is during the execution of a MOVX @DPTR instruction. During this time the Port 2 latch (the Special Function Register) does not have to contain 1s, and the contents of the Port 2 SFR are not modified. If the external memory cycle is not immediately followed by another external memory cycle, the undisturbed contents of the Port 2 SFR will reappear in the next cycle.

If an 8-bit address is being used (MOVX @Ri), the contents of the Port 2 SFR remain at the Port 2 pins throughout the external memory cycle. This will facilitate paging.

In any case, the low byte of the address is time-multiplexed with the data byte on Port 0. The ADDR/DATA signals drive both FETs in the Port 0 output buffers. Thus, in this application the Port 0 pins are not open-drain outputs, and do not require external pullups. ALE (Address Latch Enable) should be used to capture the address byte into an external latch. The address byte is valid at the negative transition of ALE. Then, in a write cycle, the data byte to be written appears on Port 0 just before \overline{WR} is activated, and remains there until after \overline{WR} is deactivated. In a read cycle, the incoming byte is accepted at Port 0 just before the read strobe is deactivated.

During any access to external memory, the CPU writes 0FFH to the Port 0 latch (the Special Function Register), thus obliterating whatever information the Port 0 SFR may have been holding.

External Program Memory is accessed under two conditions: Whenever signal \overline{EA} is active; or whenever the program counter (PC) contains a number that is larger than 0FFFH (in the 80C51).

This requires that the ROMless versions have \overline{EA} wired low to enable the lower 4k program bytes to be fetched from external memory.

When the CPU is executing out of external Program Memory, all 8 bits of Port 2 are dedicated to an output function and may not be used for general purpose I/O. During external program fetches they output the high byte of the PC. During this time the Port 2 drivers use the strong pullups to emit PC bits that are 1s.

Timer/Counters

The 80C51 has two 16-bit Timer/Counter registers: Timer 0 and Timer 1. Both can be configured to operate either as timers or event counters (see Figure 6).

In the "Timer" function, the register is incremented every machine cycle. Thus, one can think of it as counting machine cycles. Since a machine cycle consists of 12 oscillator periods, the count rate is 1/12 of the oscillator frequency.

In the "Counter" function, the register is incremented in response to a 1-to-0 transition at its corresponding external input pin, T0 or T1. In this function, the external input is sampled during S5P2 of every machine cycle.

When the samples show a high in one cycle and a low in the next cycle, the count is incremented. The new count value appears in the

register during S3P1 of the cycle following the one in which the transition was detected. Since it takes 2 machine cycles (24 oscillator periods) to recognize a 1-to-0 transition, the maximum count rate is 1/24 of the oscillator frequency. There are no restrictions on the duty cycle of the external input signal, but to ensure that a given level is sampled at least once before it changes, it should be held for at least one full cycle. In addition to the "Timer" or "Counter" selection, Timer 0 and Timer 1 have four operating modes from which to select.

Timer 0 and Timer 1

The "Timer" or "Counter" function is selected by control bits C/T in the Special Function Register TMOD. These two Timer/Counters have four operating modes, which are selected by bit-pairs (M1, M0) in TMOD. Modes 0, 1, and 2 are the same for both Timers/Counters. Mode 3 is different. The four operating modes are described in the following text.

Mode 0

Putting either Timer into Mode 0 makes it look like an 8048 Timer, which is an 8-bit Counter with a divide-by-32 prescaler. Figure 7 shows the Mode 0 operation as it applies to Timer 1.

In this mode, the Timer register is configured as a 13-bit register. As the count rolls over from all 1s to all 0s, it sets the Timer interrupt flag TF1. The counted input is enabled to the Timer when TR1 = 1 and either GATE = 0 or $\overline{INT1}$ = 1. (Setting GATE = 1 allows the Timer to be controlled by external input $\overline{INT1}$, to facilitate pulse width measurements). TR1 is a control bit in the Special Function Register TCON (Figure 8). GATE is in TMOD.

The 13-bit register consists of all 8 bits of TH1 and the lower 5 bits of TL1. The upper 3 bits of TL1 are indeterminate and should be ignored. Setting the run flag (TR1) does not clear the registers.

Mode 0 operation is the same for the Timer 0 as for Timer 1. Substitute TR0, TF0, and $\overline{INT0}$ for the corresponding Timer 1 signals in Figure 7. There are two different GATE bits, one for Timer 1 (TMOD.7) and one for Timer 0 (TMOD.3).

Mode 1

Mode 1 is the same as Mode 0, except that the Timer register is being run with all 16 bits.

Mode 2

Mode 2 configures the Timer register as an 8-bit Counter (TL1) with automatic reload, as shown in Figure 9. Overflow from TL1 not only sets TF1, but also reloads TL1 with the contents of TH1, which is preset by software. The reload leaves TH1 unchanged.

Mode 2 operation is the same for Timer/Counter 0.

Mode 3

Timer 1 in Mode 3 simply holds its count. The effect is the same as setting TR1 = 0.

Timer 0 in Mode 3 establishes TL0 and TH0 as two separate counters. The logic for Mode 3 on Timer 0 is shown in Figure 10. TL0 uses the Timer 0 control bits: C/T, GATE, TR0, INT0, and TF0. TH0 is locked into a timer function (counting machine cycles) and takes over the use of TR1 and TF1 from Timer 1. Thus, TH0 now controls the "Timer 1" interrupt.

Mode 3 is provided for applications requiring an extra 8-bit timer on the counter. With Timer 0 in Mode 3, an 80C51 can look like it has three Timer/Counters. When Timer 0 is in Mode 3, Timer 1 can be turned on and off by switching it out of and into its own Mode 3, or can still be used by the serial port as a baud rate generator, or in fact, in any application not requiring an interrupt.

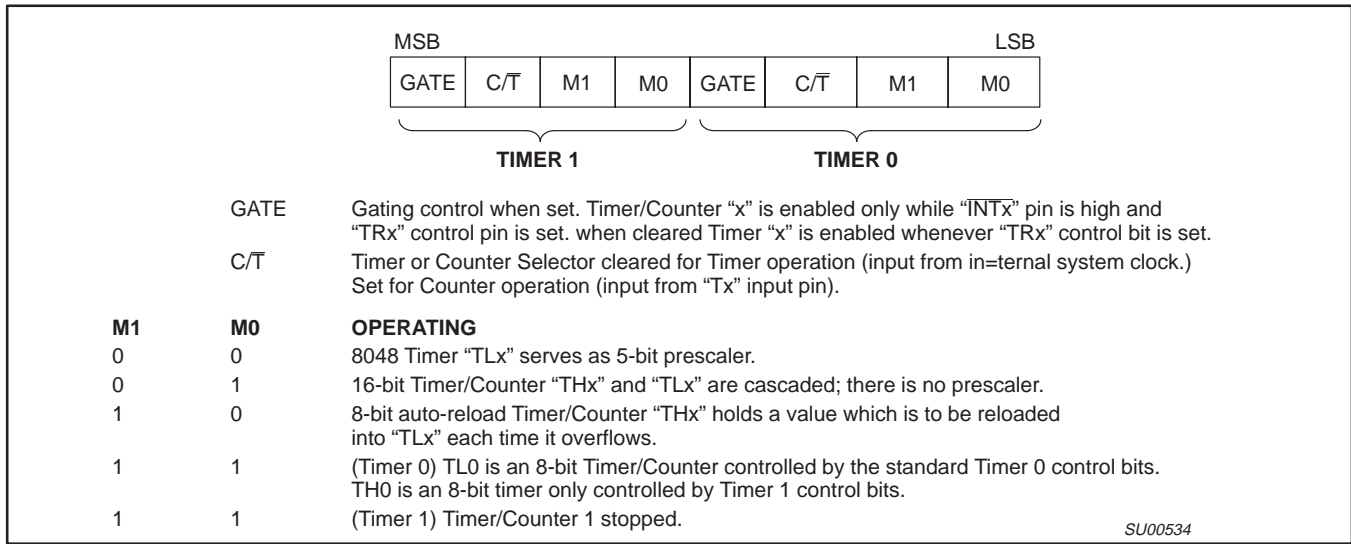

Figure 6. Timer/Counter Mode Control (TMOD) Register

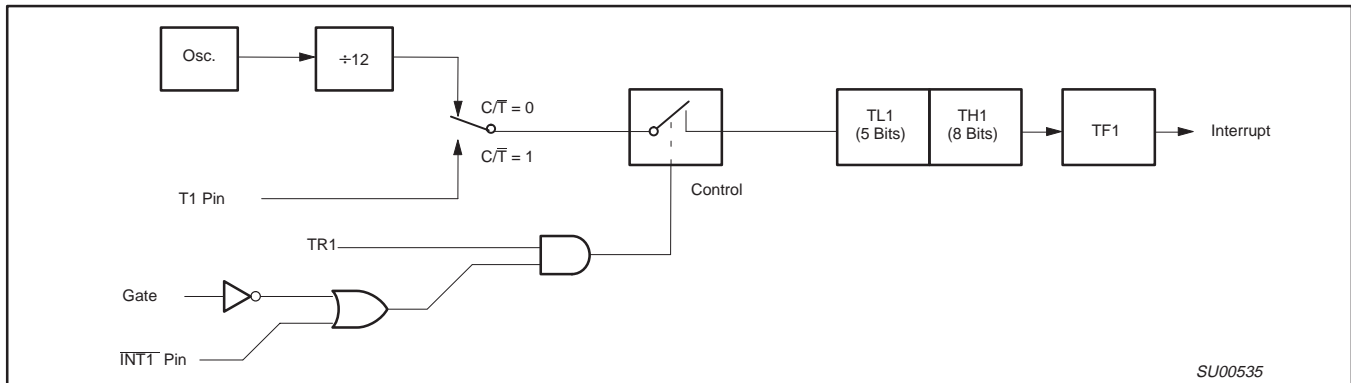

Figure 7. Timer/Counter Mode 0: 13-Bit Counter

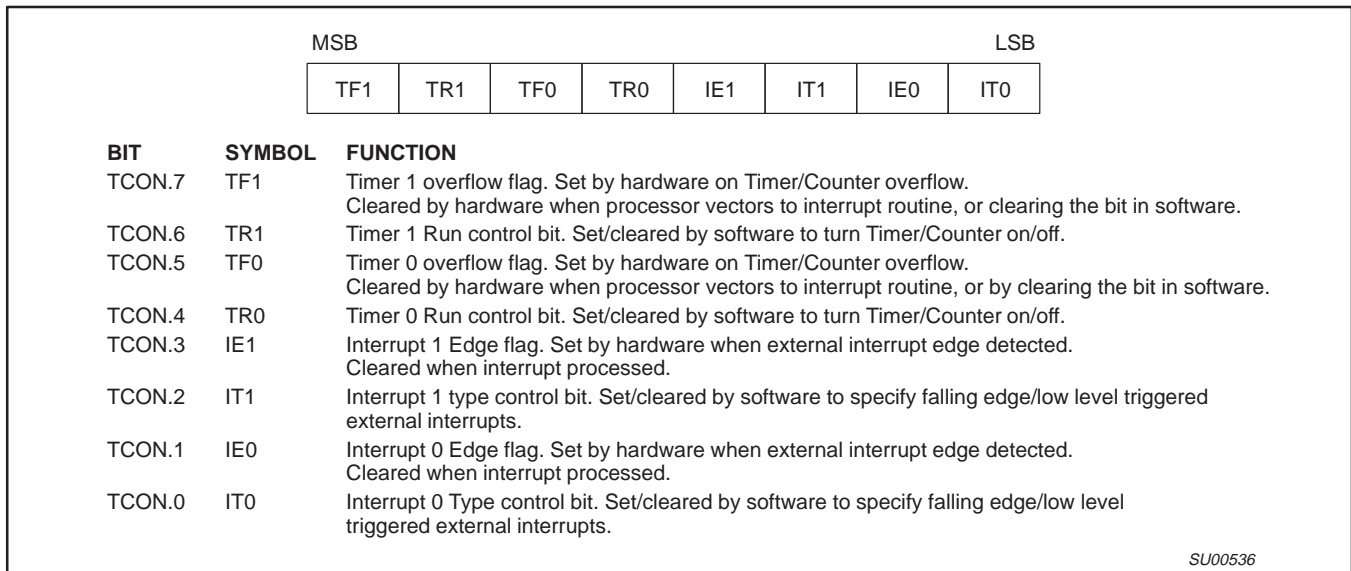

Figure 8. Timer/Counter Control (TCON) Register

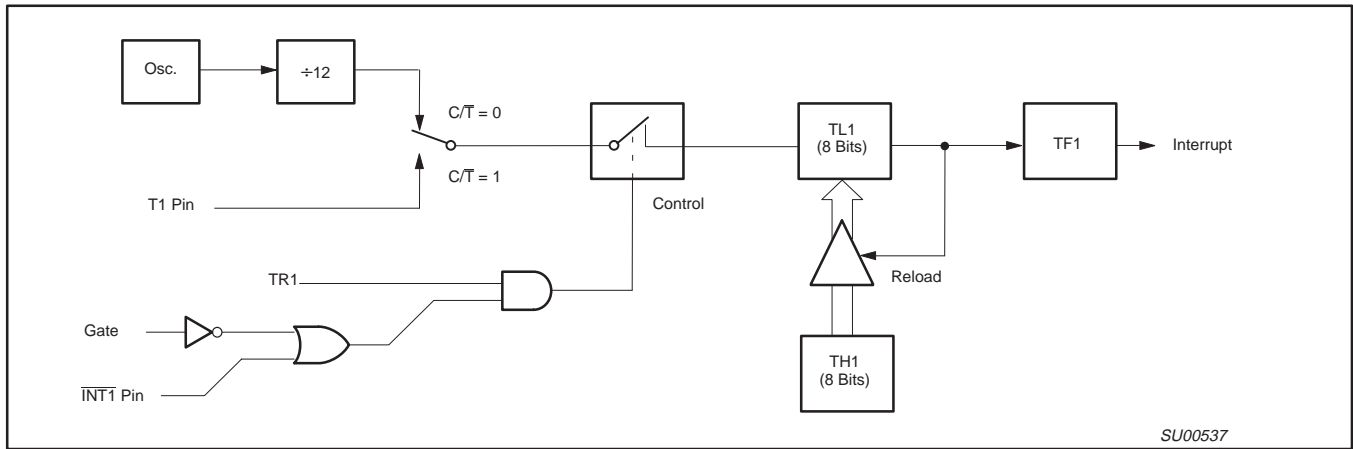

Figure 9. Timer/Counter Mode 2: 8-Bit Auto-Load

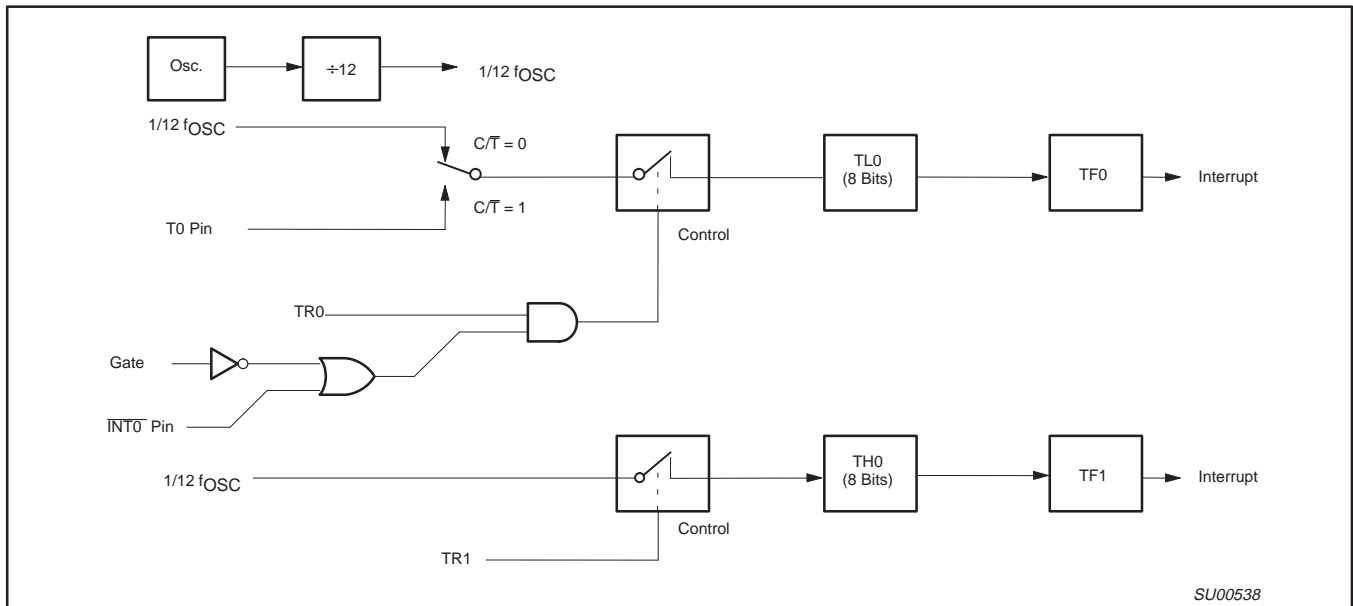

Figure 10. Timer/Counter 0 Mode 3: Two 8-Bit Counters

Standard Serial Interface

The serial port is full duplex, meaning it can transmit and receive simultaneously. It is also receive-buffered, meaning it can commence reception of a second byte before a previously received byte has been read from the register. (However, if the first byte still hasn't been read by the time reception of the second byte is complete, one of the bytes will be lost.) The serial port receive and transmit registers are both accessed at Special Function Register SBUF. Writing to SBUF loads the transmit register, and reading SBUF accesses a physically separate receive register.

The serial port can operate in 4 modes:

- Mode 0:** Serial data enters and exits through RxD. TxD outputs the shift clock. 8 bits are transmitted/received (LSB first). The baud rate is fixed at 1/12 the oscillator frequency.
- Mode 1:** 10 bits are transmitted (through TxD) or received (through RxD): a start bit (0), 8 data bits (LSB first), and a stop bit (1). On receive, the stop bit goes into RB8 in Special Function Register SCON. The baud rate is variable.
- Mode 2:** 11 bits are transmitted (through TxD) or received (through RxD): start bit (0), 8 data bits (LSB first), a programmable 9th data bit, and a stop bit (1). On Transmit, the 9th data bit (TB8 in SCON) can be assigned the value of 0 or 1. Or, for example, the parity bit (P, in the PSW) could be moved into TB8. On receive, the 9th data bit goes into RB8 in Special Function Register SCON, while the stop bit is ignored. The baud rate is programmable to either 1/32 or 1/64 the oscillator frequency.
- Mode 3:** 11 bits are transmitted (through TxD) or received (through RxD): a start bit (0), 8 data bits (LSB first), a programmable 9th data bit, and a stop bit (1). In fact, Mode 3 is the same as Mode 2 in all respects except baud rate. The baud rate in Mode 3 is variable.

In all four modes, transmission is initiated by any instruction that uses SBUF as a destination register. Reception is initiated in Mode 0 by the condition RI = 0 and REN = 1. Reception is initiated in the other modes by the incoming start bit if REN = 1.

Multiprocessor Communications

Modes 2 and 3 have a special provision for multiprocessor communications. In these modes, 9 data bits are received. The 9th one goes into RB8. Then comes a stop bit. The port can be programmed such that when the stop bit is received, the serial port interrupt will be activated only if RB8 = 1. This feature is enabled by setting bit SM2 in SCON. A way to use this feature in multiprocessor systems is as follows:

When the master processor wants to transmit a block of data to one of several slaves, it first sends out an address byte which identifies the target slave. An address byte differs from a data byte in that the 9th bit is 1 in an address byte and 0 in a data byte. With SM2 = 1, no

slave will be interrupted by a data byte. An address byte, however, will interrupt all slaves, so that each slave can examine the received byte and see if it is being addressed. The addressed slave will clear its SM2 bit and prepare to receive the data bytes that will be coming. The slaves that weren't being addressed leave their SM2s set and go on about their business, ignoring the coming data bytes.

SM2 has no effect in Mode 0, and in Mode 1 can be used to check the validity of the stop bit. In a Mode 1 reception, if SM2 = 1, the receive interrupt will not be activated unless a valid stop bit is received.

Serial Port Control Register

The serial port control and status register is the Special Function Register SCON, shown in Figure 11. This register contains not only the mode selection bits, but also the 9th data bit for transmit and receive (TB8 and RB8), and the serial port interrupt bits (TI and RI).

Baud Rates

The baud rate in Mode 0 is fixed: Mode 0 Baud Rate = Oscillator Frequency / 12. The baud rate in Mode 2 depends on the value of bit SMOD in Special Function Register PCON. If SMOD = 0 (which is the value on reset), the baud rate is 1/64 the oscillator frequency. If SMOD = 1, the baud rate is 1/32 the oscillator frequency.

Mode 2 Baud Rate =

$$\frac{2^{SMOD}}{64} \times (\text{Oscillator Frequency})$$

In the 80C51, the baud rates in Modes 1 and 3 are determined by the Timer 1 overflow rate.

Using Timer 1 to Generate Baud Rates

When Timer 1 is used as the baud rate generator, the baud rates in Modes 1 and 3 are determined by the Timer 1 overflow rate and the value of SMOD as follows:

Mode 1, 3 Baud Rate =

$$\frac{2^{SMOD}}{32} \times (\text{Timer 1 Overflow Rate})$$

The Timer 1 interrupt should be disabled in this application. The Timer itself can be configured for either "timer" or "counter" operation, and in any of its 3 running modes. In the most typical applications, it is configured for "timer" operation, in the auto-reload mode (high nibble of TMOD = 0010B). In that case the baud rate is given by the formula:

Mode 1, 3 Baud Rate =

$$\frac{2^{SMOD}}{32} \times \frac{\text{Oscillator Frequency}}{12 \times [256 - (TH1)]}$$

One can achieve very low baud rates with Timer 1 by leaving the Timer 1 interrupt enabled, and configuring the Timer to run as a 16-bit timer (high nibble of TMOD = 0001B), and using the Timer 1 interrupt to do a 16-bit software reload. Figure 12 lists various commonly used baud rates and how they can be obtained from Timer 1.

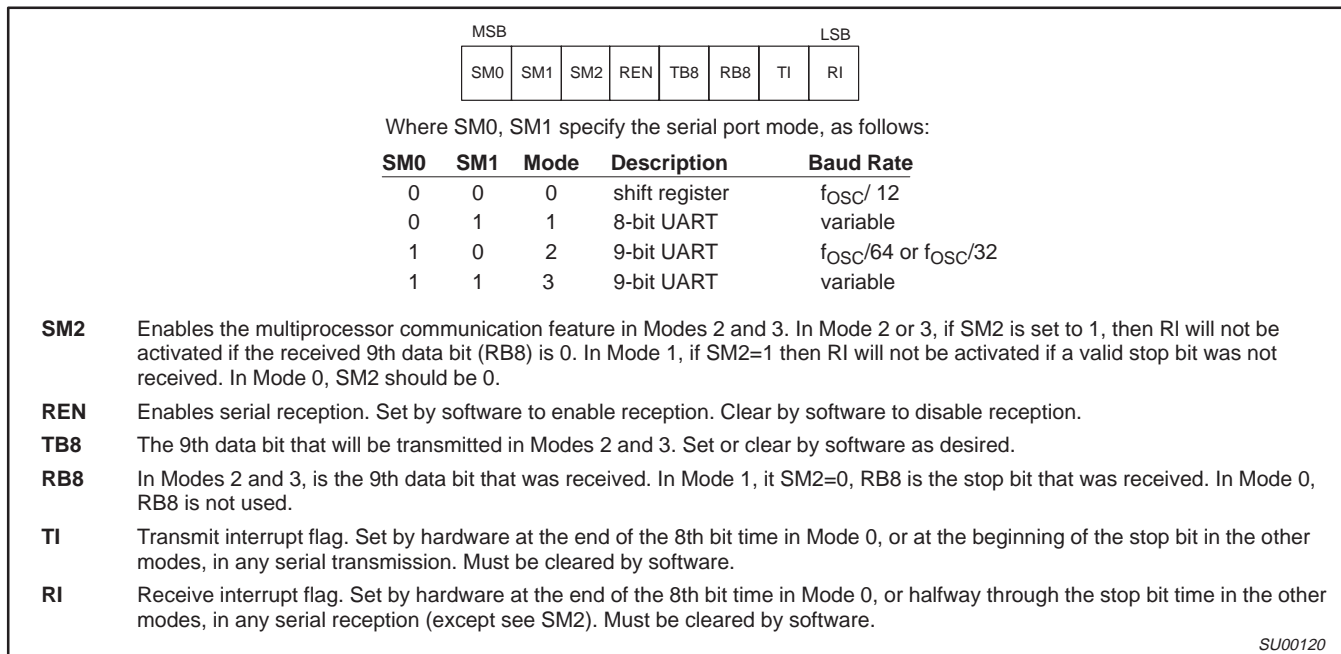

Figure 11. Serial Port Control (SCON) Register

Baud Rate	f _{osc}	SMOD	Timer 1		
			C/T	Mode	Reload Value
Mode 0 Max: 1.67MHz	20MHz	X	X	X	X
Mode 2 Max: 625k	20MHz	1	X	X	X
Mode 1, 3 Max: 104.2k	20MHz	1	0	2	FFH
19.2k	11.059MHz	1	0	2	FDH
9.6k	11.059MHz	0	0	2	FDH
4.8k	11.059MHz	0	0	2	FAH
2.4k	11.059MHz	0	0	2	F4H
1.2k	11.059MHz	0	0	2	E8H
137.5	11.986MHz	0	0	2	1DH
110	6MHz	0	0	2	72H
110	12MHz	0	0	1	FEEDH

Figure 12. Timer 1 Generated Commonly Used Baud Rates

More About Mode 0

Serial data enters and exits through RxD. TxD outputs the shift clock. 8 bits are transmitted/received: 8 data bits (LSB first). The baud rate is fixed a 1/12 the oscillator frequency.

Figure 13 shows a simplified functional diagram of the serial port in Mode 0, and associated timing.

Transmission is initiated by any instruction that uses SBUF as a destination register. The "write to SBUF" signal at S6P2 also loads a 1 into the 9th position of the transmit shift register and tells the TX Control block to commence a transmission. The internal timing is such that one full machine cycle will elapse between "write to SBUF" and activation of SEND.

SEND enables the output of the shift register to the alternate output function line of P3.0 and also enable SHIFT CLOCK to the alternate output function line of P3.1. SHIFT CLOCK is low during S3, S4, and S5 of every machine cycle, and high during S6, S1, and S2. At S6P2 of every machine cycle in which SEND is active, the contents of the transmit shift are shifted to the right one position.

As data bits shift out to the right, zeros come in from the left. When the MSB of the data byte is at the output position of the shift register, then the 1 that was initially loaded into the 9th position, is just to the left of the MSB, and all positions to the left of that contain zeros. This condition flags the TX Control block to do one last shift and then deactivate SEND and set T1. Both of these actions occur at S1P1 of the 10th machine cycle after "write to SBUF."

Reception is initiated by the condition REN = 1 and R1 = 0. At S6P2 of the next machine cycle, the RX Control unit writes the bits 11111110 to the receive shift register, and in the next clock phase activates RECEIVE.

RECEIVE enable SHIFT CLOCK to the alternate output function line of P3.1. SHIFT CLOCK makes transitions at S3P1 and S6P1 of every machine cycle. At S6P2 of every machine cycle in which RECEIVE is active, the contents of the receive shift register are shifted to the left one position. The value that comes in from the right is the value that was sampled at the P3.0 pin at S5P2 of the same machine cycle.

As data bits come in from the right, 1s shift out to the left. When the 0 that was initially loaded into the rightmost position arrives at the leftmost position in the shift register, it flags the RX Control block to do one last shift and load SBUF. At S1P1 of the 10th machine cycle after the write to SCON that cleared RI, RECEIVE is cleared as RI is set.

More About Mode 1

Ten bits are transmitted (through TxD), or received (through RxD): a start bit (0), 8 data bits (LSB first), and a stop bit (1). On receive, the stop bit goes into RB8 in SCON. In the 80C51 the baud rate is determined by the Timer 1 overflow rate.

Figure 14 shows a simplified functional diagram of the serial port in Mode 1, and associated timings for transmit receive.

Transmission is initiated by any instruction that uses SBUF as a destination register. The "write to SBUF" signal also loads a 1 into the 9th bit position of the transmit shift register and flags the TX Control unit that a transmission is requested. Transmission actually commences at S1P1 of the machine cycle following the next rollover in the divide-by-16 counter. (Thus, the bit times are synchronized to the divide-by-16 counter, not to the "write to SBUF" signal.)

The transmission begins with activation of SEND which puts the start bit at TxD. One bit time later, DATA is activated, which enables the output bit of the transmit shift register to TxD. The first shift pulse occurs one bit time after that.

As data bits shift out to the right, zeros are clocked in from the left. When the MSB of the data byte is at the output position of the shift register, then the 1 that was initially loaded into the 9th position is just to the left of the MSB, and all positions to the left of that contain zeros. This condition flags the TX Control unit to do one last shift and then deactivate SEND and set TI. This occurs at the 10th divide-by-16 rollover after "write to SBUF."

Reception is initiated by a detected 1-to-0 transition at RxD. For this purpose RxD is sampled at a rate of 16 times whatever baud rate has been established. When a transition is detected, the divide-by-16 counter is immediately reset, and 1FFH is written into the input shift register. Resetting the divide-by-16 counter aligns its rollovers with the boundaries of the incoming bit times.

The 16 states of the counter divide each bit time into 16ths. At the 7th, 8th, and 9th counter states of each bit time, the bit detector samples the value of RxD. The value accepted is the value that was seen in at least 2 of the 3 samples. This is done for noise rejection. If the value accepted during the first bit time is not 0, the receive circuits are reset and the unit goes back to looking for another 1-to-0 transition. This is to provide rejection of false start bits. If the start bit proves valid, it is shifted into the input shift register, and reception of the rest of the frame will proceed.

As data bits come in from the right, 1s shift out to the left. When the start bit arrives at the leftmost position in the shift register (which in mode 1 is a 9-bit register), it flags the RX Control block to do one last shift, load SBUF and RB8, and set RI. The signal to load SBUF and RB8, and to set RI, will be generated if, and only if, the following conditions are met at the time the final shift pulse is generated.:

1. R1 = 0, and
2. Either SM2 = 0, or the received stop bit = 1.

If either of these two conditions is not met, the received frame is irretrievably lost. If both conditions are met, the stop bit goes into RB8, the 8 data bits go into SBUF, and RI is activated. At this time, whether the above conditions are met or not, the unit goes back to looking for a 1-to-0 transition in RxD.

More About Modes 2 and 3

Eleven bits are transmitted (through TxD), or received (through RxD): a start bit (0), 8 data bits (LSB first), a programmable 9th data bit, and a stop bit (1). On transmit, the 9th data bit (TB8) can be assigned the value of 0 or 1. On receive, the 9th data bit goes into RB8 in SCON. The baud rate is programmable to either 1/32 or 1/64 the oscillator frequency in Mode 2. Mode 3 may have a variable baud rate generated from Timer 1.

Figures 15 and 16 show a functional diagram of the serial port in Modes 2 and 3. The receive portion is exactly the same as in Mode 1. The transmit portion differs from Mode 1 only in the 9th bit of the transmit shift register.

Transmission is initiated by any instruction that uses SBUF as a destination register. The "write to SBUF" signal also loads TB8 into the 9th bit position of the transmit shift register and flags the TX Control unit that a transmission is requested. Transmission commences at S1P1 of the machine cycle following the next rollover in the divide-by-16 counter. (Thus, the bit times are synchronized to the divide-by-16 counter, not to the "write to SBUF" signal.)

The transmission begins with activation of SEND, which puts the start bit at TxD. One bit time later, DATA is activated, which enables the output bit of the transmit shift register to TxD. The first shift pulse occurs one bit time after that. The first shift clocks a 1 (the stop bit) into the 9th bit position of the shift register. Thereafter, only zeros are clocked in. Thus, as data bits shift out to the right, zeros are clocked in from the left. When TB8 is at the output position of the shift register, then the stop bit is just to the left of TB8, and all positions to the left of that contain zeros. This condition flags the TX Control unit to do one last shift and then deactivate SEND and set TI. This occurs at the 11th divide-by-16 rollover after "write to SBUF."

Reception is initiated by a detected 1-to-0 transition at RxD. For this purpose RxD is sampled at a rate of 16 times whatever baud rate has been established. When a transition is detected, the divide-by-16 counter is immediately reset, and 1FFH is written to the input shift register.

At the 7th, 8th, and 9th counter states of each bit time, the bit detector samples the value of R-D. The value accepted is the value that was seen in at least 2 of the 3 samples. If the value accepted during the first bit time is not 0, the receive circuits are reset and the unit goes back to looking for another 1-to-0 transition. If the start bit proves valid, it is shifted into the input shift register, and reception of the rest of the frame will proceed.

As data bits come in from the right, 1s shift out to the left. When the start bit arrives at the leftmost position in the shift register (which in Modes 2 and 3 is a 9-bit register), it flags the RX Control block to do one last shift, load SBUF and RB8, and set RI.

The signal to load SBUF and RB8, and to set RI, will be generated if, and only if, the following conditions are met at the time the final shift pulse is generated.

1. RI = 0, and
2. Either SM2 = 0, or the received 9th data bit = 1.

If either of these conditions is not met, the received frame is irretrievably lost, and RI is not set. If both conditions are met, the received 9th data bit goes into RB8, and the first 8 data bits go into SBUF. One bit time later, whether the above conditions were met or not, the unit goes back to looking for a 1-to-0 transition at the RxD input.

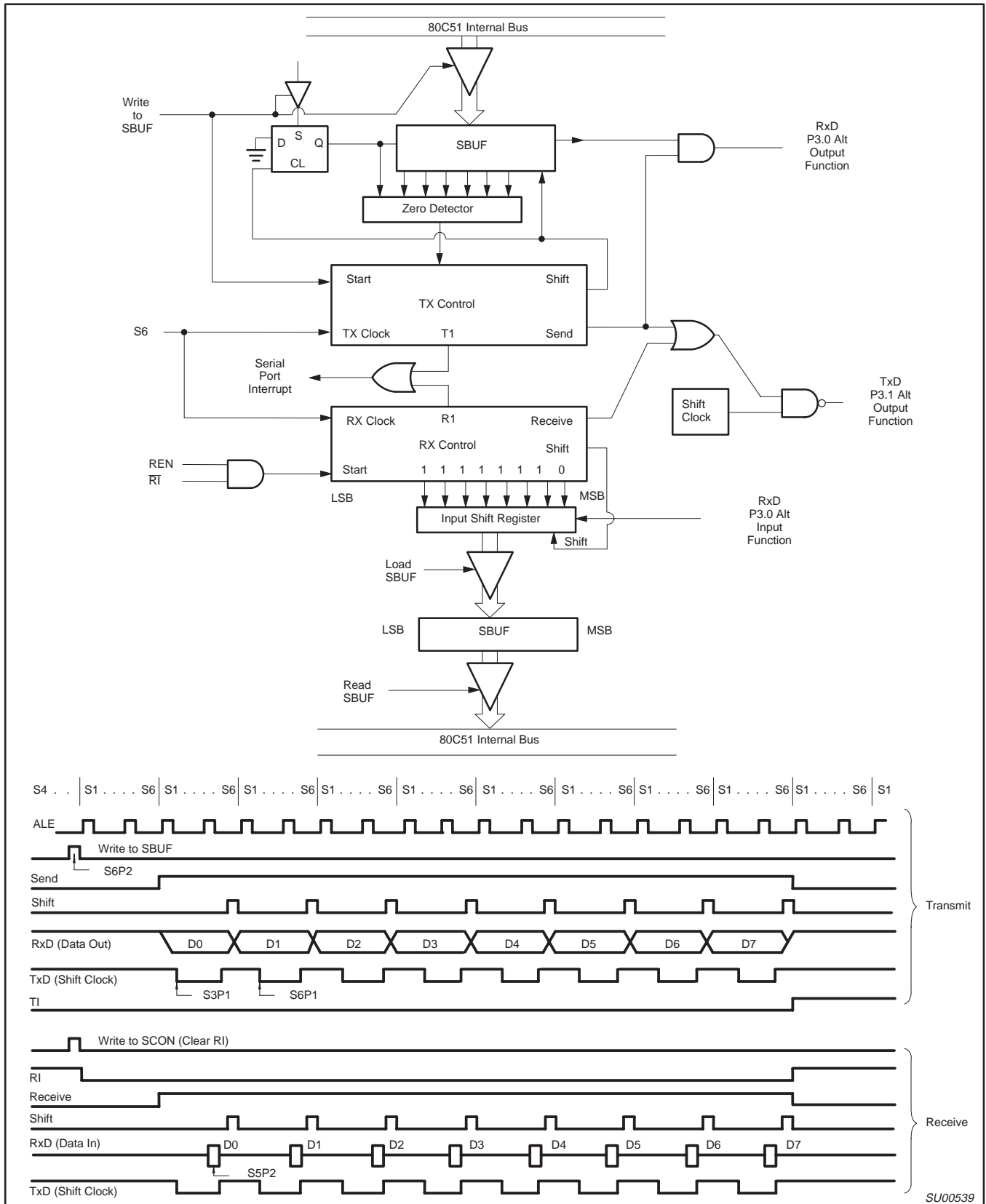
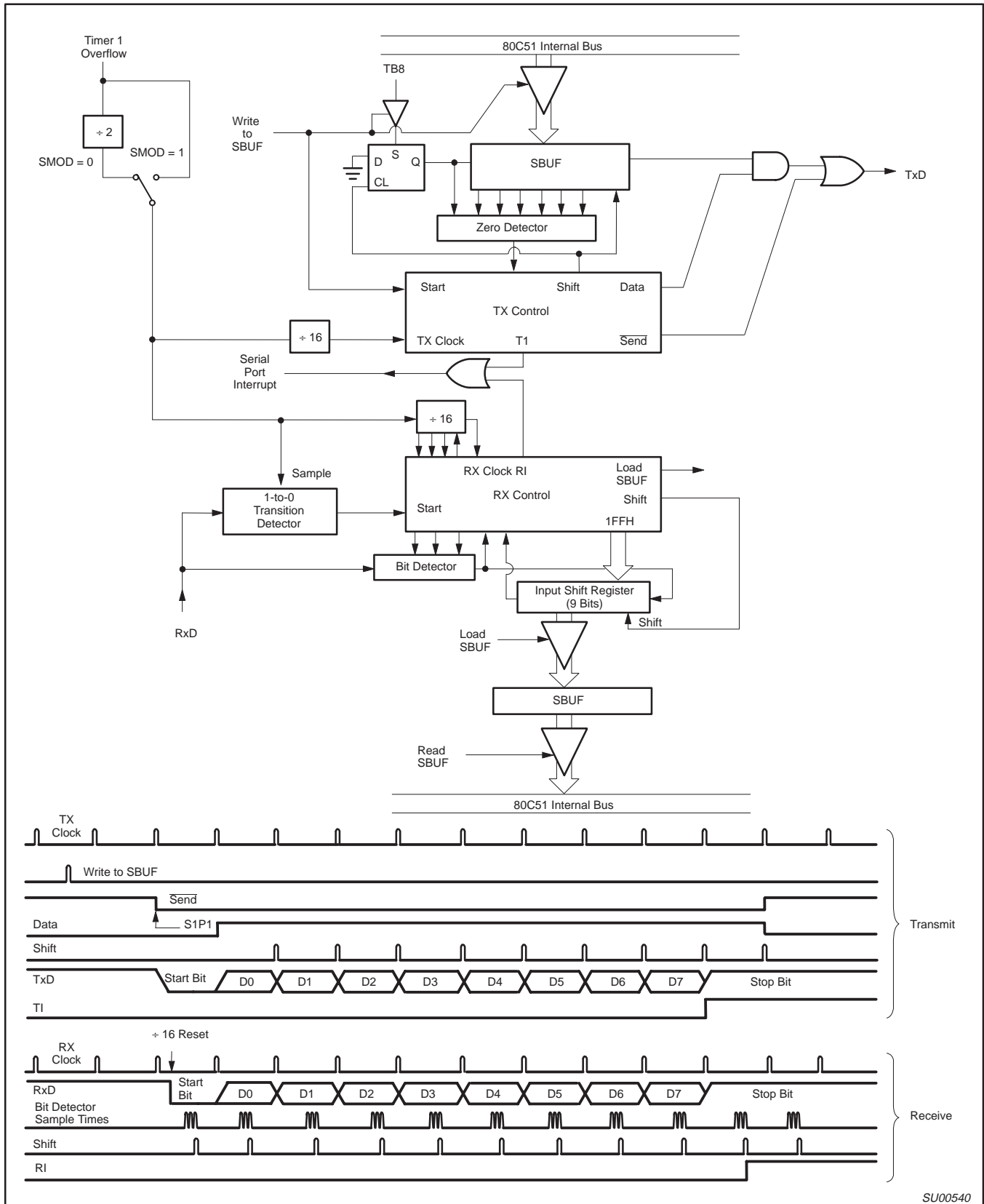

Figure 13. Serial Port Mode 0

SU00539



SU00540

Figure 14. Serial Port Mode 1

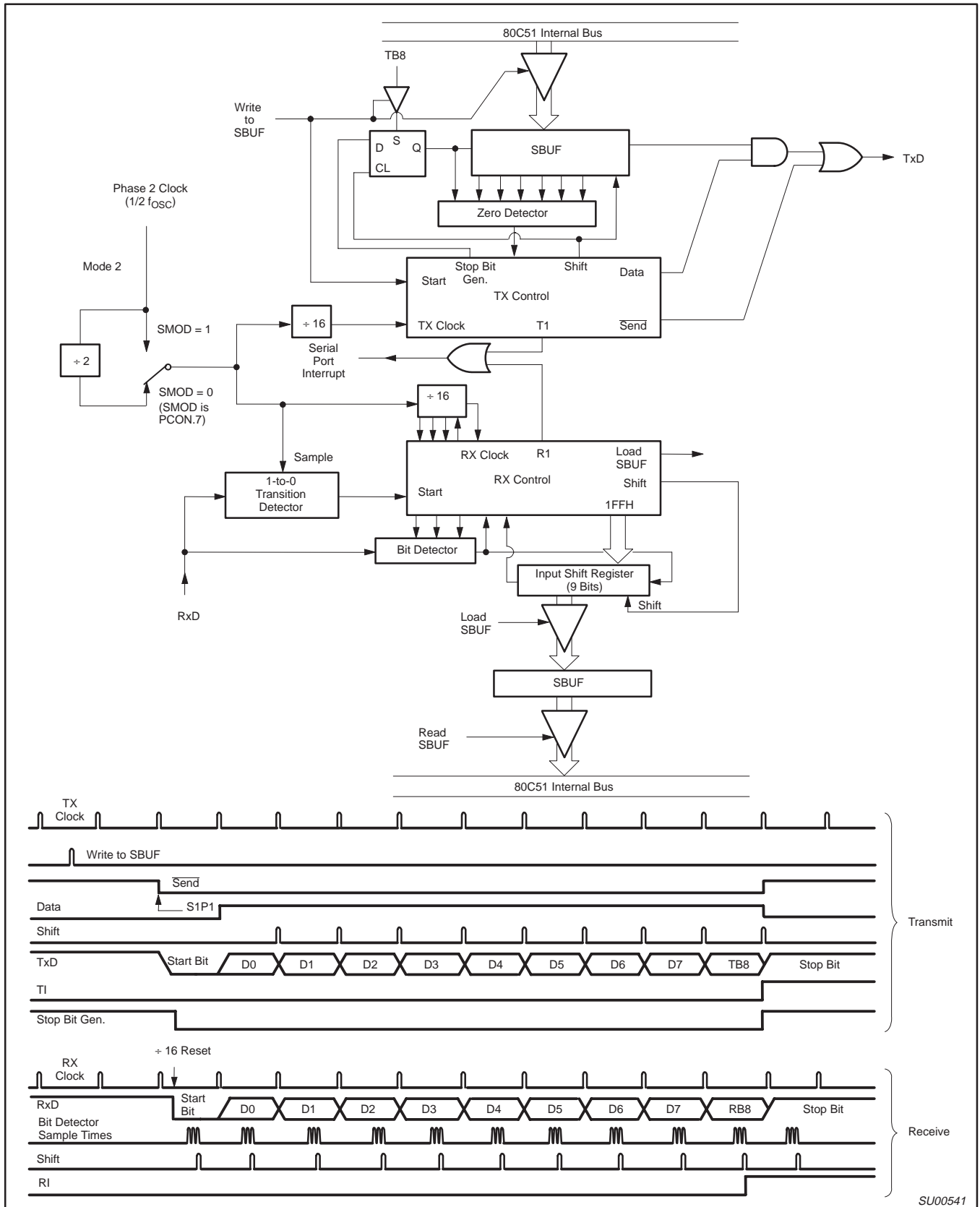

Figure 15. Serial Port Mode 2

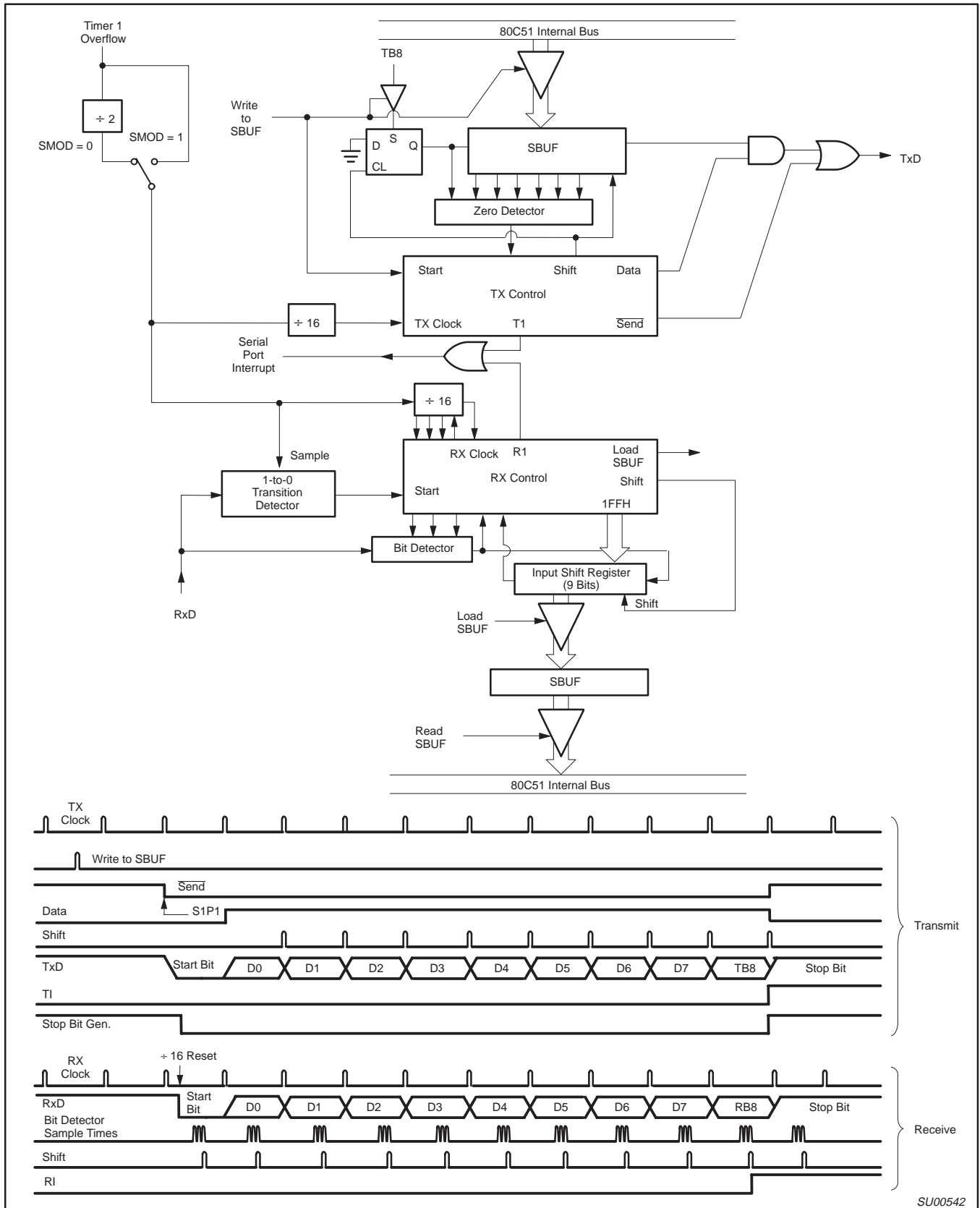

Figure 16. Serial Port Mode 3

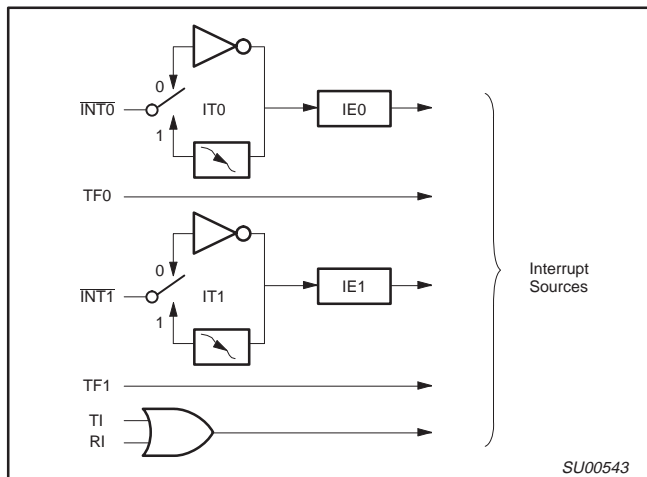

Figure 17. 80C51 Interrupt Sources

Interrupts

The 80C51 provides 5 interrupt sources. These are shown in Figure 17. The External Interrupts INT0 and INT1 can each be either level-activated or transition-activated, depending on bits IT0 and IT1 in Register TCON. The flags that actually generate these interrupts are bits IE0 and IE1 in TCON. When an external interrupt is generated, the flag that generated it is cleared by the hardware when the service routine is vectored to only if the interrupt was transition-activated. If the interrupt was level-activated, then the external requesting source is what controls the request flag, rather than the on-chip hardware.

The Timer 0 and Timer 1 Interrupts are generated by TF0 and TF1, which are set by a rollover in their respective Timer/Counter registers (except see Timer 0 in Mode 3). When a timer interrupt is generated, the flag that generated it is cleared by the on-chip hardware when the service routine is vectored to.

The Serial Port Interrupt is generated by the logical OR of RI and TI. Neither of these flags is cleared by hardware when the service routine is vectored to. In fact, the service routine will normally have to determine whether it was RI or TI that generated the interrupt, and the bit will have to be cleared in software.

All of the bits that generate interrupts can be set or cleared by software, with the same result as though it had been set or cleared by hardware. That is, interrupts can be generated or pending interrupts can be canceled in software.

Each of these interrupt sources can be individually enabled or disabled by setting or clearing a bit in Special Function Register IE (Figure 18). IE also contains a global disable bit, EA, which disables all interrupts at once.

Priority Level Structure

Each interrupt source can also be individually programmed to one of two priority levels by setting or clearing a bit in Special Function

Register IP (Figure 19). A low-priority interrupt can itself be interrupted by a high-priority interrupt, but not by another low-priority interrupt. A high-priority interrupt can't be interrupted by any other interrupt source.

If two request of different priority levels are received simultaneously, the request of higher priority level is serviced. If requests of the same priority level are received simultaneously, an internal polling sequence determines which request is serviced. Thus within each priority level there is a second priority structure determined by the polling sequence as follows:

Source	Priority Within Level
1. IE0	(highest)
2. TF0	
3. IE1	
4. TF1	
5. RI+TI	(lowest)

Note that the "priority within level" structure is only used to resolve simultaneous requests of the same priority level.

The IP register contains a number of unimplemented bits. IP.7, IP.6, and IP.5 are reserved in the 80C51. User software should not write 1s to these positions, since they may be used in other 8051 Family products.

How Interrupts Are Handled

The interrupt flags are sampled at S5P2 of every machine cycle. The samples are polled during the following machine cycle. If one of the flags was in a set condition at S5P2 of the preceding cycle, the polling cycle will find it and the interrupt system will generate an LCALL to the appropriate service routine, provided this hardware-generated LCALL is not blocked by any of the following conditions:

1. An interrupt of equal or higher priority level is already in progress.
2. The current (polling) cycle is not the final cycle in the execution of the instruction in progress.
3. The instruction in progress is RETI or any write to the IE or IP registers.

Any of these three conditions will block the generation of the LCALL to the interrupt service routine. Condition 2 ensures that the instruction in progress will be completed before vectoring to any service routine. Condition 3 ensures that if the instruction in progress is RETI or any access to IE or IP, then at least one more instruction will be executed before any interrupt is vectored to.

The polling cycle is repeated with each machine cycle, and the values polled are the values that were present at S5P2 of the previous machine cycle. Note that if an interrupt flag is active but not being responded to for one of the above conditions, if the flag is not still active when the blocking condition is removed, the denied interrupt will not be serviced. In other words, the fact that the interrupt flag was once active but not serviced is not remembered. Every polling cycle is new.

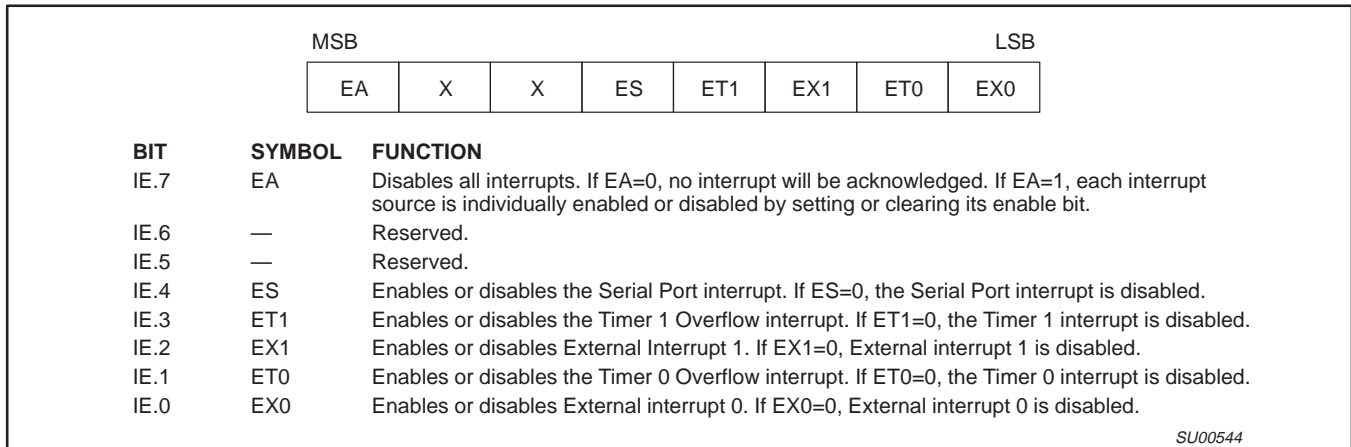

Figure 18. Interrupt Enable Register (IE)

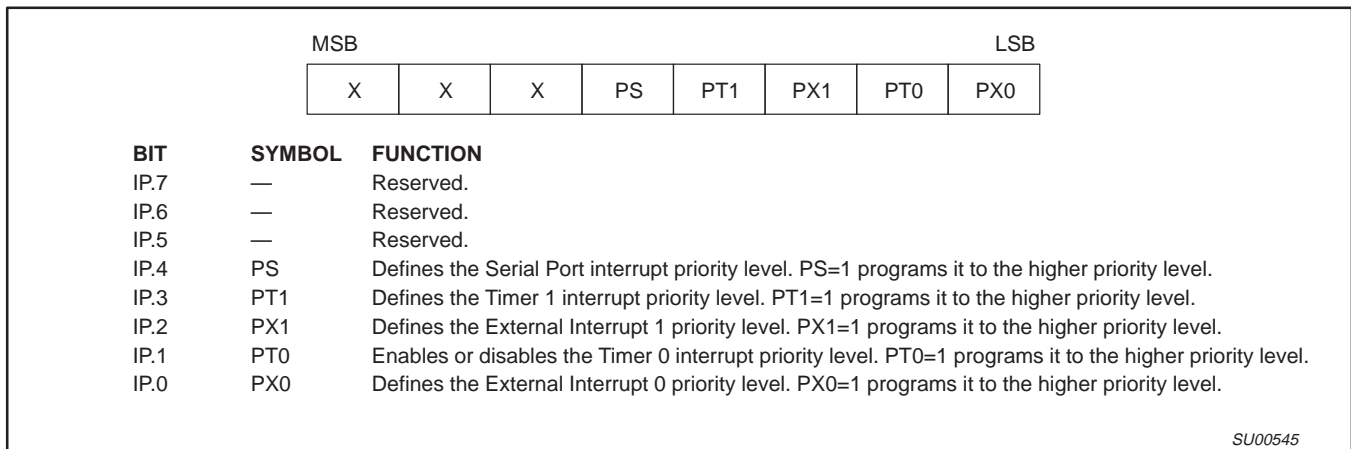

Figure 19. Interrupt Priority Register (IP)

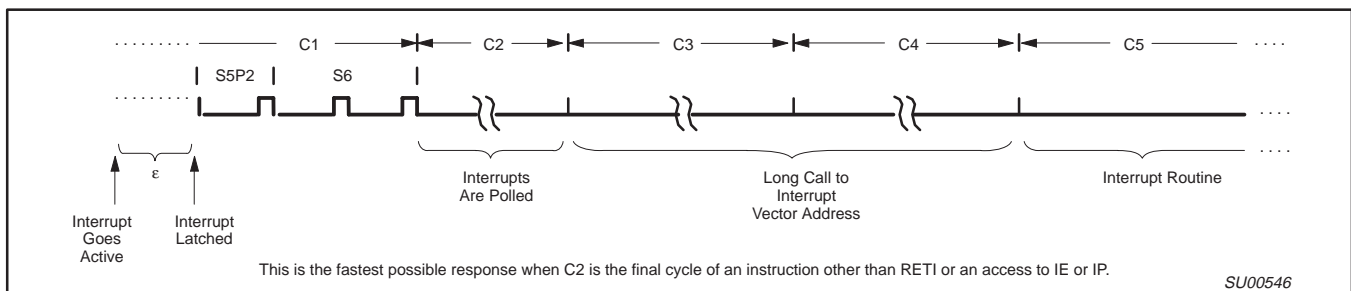

Figure 20. Interrupt Response Timing Diagram

The polling cycle/LCALL sequence is illustrated in Figure 20.

Note that if an interrupt of higher priority level goes active prior to S5P2 of the machine cycle labeled C3 in Figure 20, then in accordance with the above rules it will be vectored to during C5 and C6, without any instruction of the lower priority routine having been executed.

Thus the processor acknowledges an interrupt request by executing a hardware-generated LCALL to the appropriate servicing routine. In some cases it also clears the flag that generated the interrupt, and in other cases it doesn't. It never clears the Serial Port flag. This has to be done in the user's software. It clears an external interrupt flag (IE0 or IE1) only if it was transition-activated. The

hardware-generated LCALL pushes the contents of the Program Counter on to the stack (but it does not save the PSW) and reloads the PC with an address that depends on the source of the interrupt being vectored to, as shown below:

Source	Vector Address
IE0	0003H
TF0	000BH
IE1	0013H
TF1	001BH
RI+TI	0023H

Execution proceeds from that location until the RETI instruction is encountered. The RETI instruction informs the processor that this

interrupt routine is no longer in progress, then pops the top two bytes from the stack and reloads the Program Counter. Execution of the interrupted program continues from where it left off.

Note that a simple RET instruction would also have returned execution to the interrupted program, but it would have left the interrupt control system thinking an interrupt was still in progress, making future interrupts impossible.

External Interrupts

The external sources can be programmed to be level-activated or transition-activated by setting or clearing bit IT1 or IT0 in Register TCON. If ITx = 0, external interrupt x is triggered by a detected low at the INTx pin. If ITx = 1, external interrupt x is edge triggered. In this mode if successive samples of the INTx pin show a high in one cycle and a low in the next cycle, interrupt request flag IEx in TCON is set. Flag bit IEx then requests the interrupt.

Since the external interrupt pins are sampled once each machine cycle, an input high or low should hold for at least 12 oscillator periods to ensure sampling. If the external interrupt is transition-activated, the external source has to hold the request pin high for at least one cycle, and then hold it low for at least one cycle. This is done to ensure that the transition is seen so that interrupt request flag IEx will be set. IEx will be automatically cleared by the CPU when the service routine is called.

If the external interrupt is level-activated, the external source has to hold the request active until the requested interrupt is actually generated. Then it has to deactivate the request before the interrupt service routine is completed, or else another interrupt will be generated.

Response Time

The INT0 and INT1 levels are inverted and latched into IE0 and IE1 at S5P2 of every machine cycle. The values are not actually polled by the circuitry until the next machine cycle. If a request is active and conditions are right for it to be acknowledged, a hardware subroutine call to the requested service routine will be the next instruction to be executed. The call itself takes two cycles. Thus, a minimum of three complete machine cycles elapse between activation of an external interrupt request and the beginning of execution of the first instruction of the service routine. Figure 20 shows interrupt response timings.

A longer response time would result if the request is blocked by one of the 3 previously listed conditions. If an interrupt of equal or higher priority level is already in progress, the additional wait time obviously depends on the nature of the other interrupt's service routine. If the instruction in progress is not in its final cycle, the additional wait time cannot be more the 3 cycles, since the longest instructions (MUL and DIV) are only 4 cycles long, and if the instruction in progress is RETI or an access to IE or IP, the additional wait time cannot be more than 5 cycles (a maximum of one more cycle to complete the instruction in progress, plus 4 cycles to complete the next instruction if the instruction is MUL or DIV).

Thus, in a single-interrupt system, the response time is always more than 3 cycles and less than 9 cycles.

Single-Step Operation

The 80C51 interrupt structure allows single-step execution with very little software overhead. As previously noted, an interrupt request will not be responded to while an interrupt of equal priority level is still in progress, nor will it be responded to after RETI until at least

one other instruction has been executed. Thus, once an interrupt routine has been entered, it cannot be re-entered until at least one instruction of the interrupted program is executed. One way to use this feature for single-step operation is to program one of the external interrupts (e.g., INT0) to be level-activated. The service routine for the interrupt will terminate with the following code:

```
JNB P3.2,$ ;Wait Till INT0 Goes High
JB P3.2,$ ;Wait Till INT0 Goes Low
RETI ;Go Back and Execute One Instruction
```

Now if the INT0 pin, which is also the P3.2 pin, is held normally low, the CPU will go right into the External Interrupt 0 routine and stay there until INT0 is pulsed (from low to high to low). Then it will execute RETI, go back to the task program, execute one instruction, and immediately re-enter the External Interrupt 0 routine to await the next pulsing of P3.2. One step of the task program is executed each time P3.2 is pulsed.

Reset

The reset input is the RST pin, which is the input to a Schmitt Trigger. A reset is accomplished by holding the RST pin high for at least two machine cycles (24 oscillator periods), while the oscillator is running. The CPU responds by generating an internal reset, with the timing shown in Figure 21.

The external reset signal is asynchronous to the internal clock. The RST pin is sampled during State 5 Phase 2 of every machine cycle. The port pins will maintain their current activities for 19 oscillator periods after a logic 1 has been sampled at the RST pin; that is, for 19 to 31 oscillator periods after the external reset signal has been applied to the RST pin.

The internal reset algorithm writes 0s to all the SFRs except the port latches, the Stack Pointer, and SBUF. The port latches are initialized to FFH, the Stack Pointer to 07H, and SBUF is indeterminate. Table 1 lists the SFR reset values. The internal RAM is not affected by reset. On power up the RAM content is indeterminate.

Table 1. 80C51 SFR Reset Values

REGISTER	RESET VALUE
PC	000H
ACC	00H
B	00H
PSW	00H
SP	07H
DPTR	0000H
P0-P3	FFH
IP	XXX00000B
IE	0XX00000B
TMOD	00H
TCON	00H
TH0	00H
TL0	00H
TH1	00H
TL1	00H
SCON	00H
SBUF	Indeterminate
PCON (NMOS)	0XXXXXXXB
PCON (CMOS)	0XX0000B

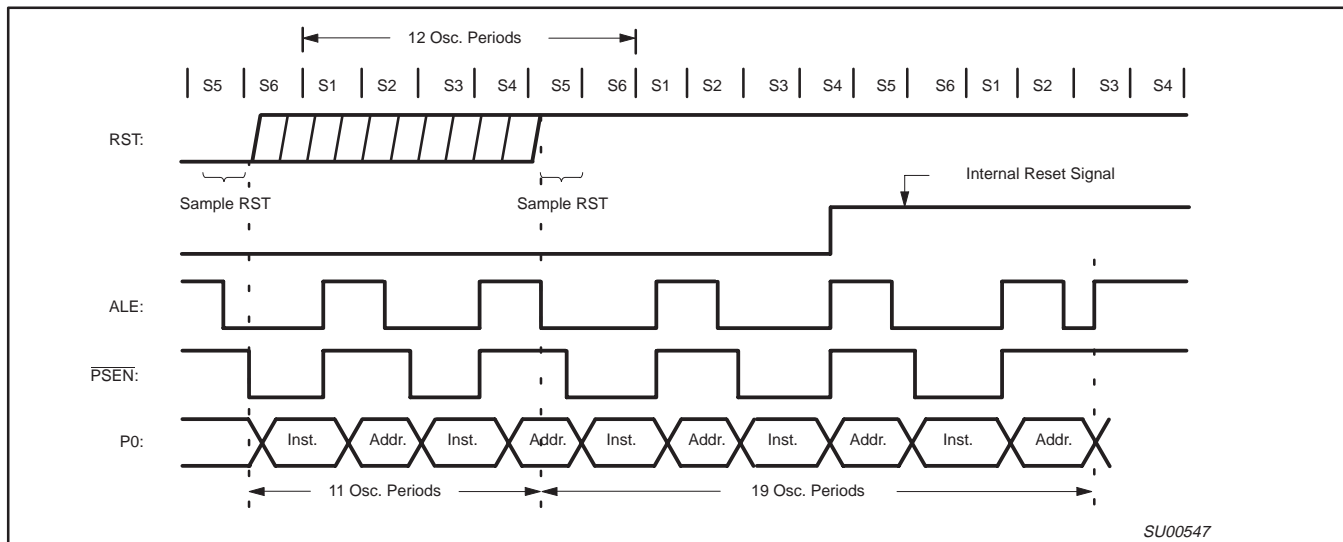

Figure 21. Reset Timing

Power-on Reset

An automatic reset can be obtained when V_{CC} is turned on by connecting the RST pin to V_{CC} through a $10\mu\text{f}$ capacitor and to V_{SS} through an 8.2k resistor, providing the V_{CC} rise time does not exceed 1 millisecond and the oscillator start-up time does not exceed 10 milliseconds. This power-on reset circuit is shown in Figure 22. The CMOS devices do not require the 8.2k pulldown resistor, although its presence does no harm.

When power is turned on, the circuit holds the RST pin high for an amount of time that depends on the value of the capacitor and the rate at which it charges. To ensure a good reset, the RST pin must be high long enough to allow the oscillator time to start-up (normally a few ms) plus two machine cycles.

Note that the port pins will be in a random state until the oscillator has started and the internal reset algorithm has written 1s to them.

With this circuit, reducing V_{CC} quickly to 0 causes the RST pin voltage to momentarily fall below 0V. However, this voltage is internally limited, and will not harm the device.

Power-Saving Modes of Operation

For applications where power consumption is critical the CMOS version provides power reduced modes of operation as a standard feature. The power down mode in NMOS devices is no longer a standard feature.

CMOS Power Reduction Mode

CMOS versions have two power reducing modes, Idle and Power Down. The input through which backup power is supplied during these operations is V_{CC} . Figure 23 shows the internal circuitry which implements these features. In the Idle modes ($IDL = 1$), the oscillator continues to run and the Interrupt, Serial Port, and Timer blocks continue to be clocked, but the clock signal is gated off to the CPU. In Power Down ($PD = 1$), the oscillator is frozen. The Idle and Power Down Modes are activated by setting bits in Special Function Register PCON. The address of this register is 87H. Figure 24 details its contents.

In the NMOS devices the PCON register only contains SMOD. The other four bits are implemented only in the CMOS devices. User

software should never write 1s to unimplemented bits, since they may be used in other 80C51 Family products.

Idle Mode

An instruction that sets PCON.0 causes that to be the last instruction executed before going into the Idle mode, the internal clock signal is gated off to the CPU but not to the Interrupt, Timer, and Serial Port functions. The CPU status is preserved in its entirety; the Stack Pointer, Program Counter, Program Status Word, Accumulator, and all other registers maintain their data during Idle. The port pins hold the logical states they had at the time Idle was activated. ALE and PSEN hold at logic high levels.

There are two ways to terminate the Idle. Activation of any enabled interrupt will cause PCON.0 to be cleared by hardware, terminating the Idle mode. The interrupt will be serviced, and following RETI, the next instruction to be executed will be the one following the instruction that put the device into Idle.

The flag bits GF0 and GF1 can be used to give an indication if an interrupt occurred during normal operation or during an Idle. For example, an instruction that activates Idle can also set one or both flag bits. When Idle is terminated by an interrupt, the interrupt service routine can examine the flag bits. The other way of terminating the Idle mode is with a hardware reset. Since the clock oscillator is still running, the hardware reset needs to be held active for only two machine cycles (24 oscillator periods) to complete the reset.

The signal at the RST pin clears the IDL bit directly and asynchronously. At this time the CPU resumes program execution from where it left off; that is, at the instruction following the one that invoked the Idle Mode. As shown in Figure 21, two or three machine cycles of program execution may take place before the internal reset algorithm takes control. On-chip hardware inhibits access to the internal RAM during this time, but access to the port pins is not inhibited, so, the insertion of 3 NOP instructions is recommended following the instruction that invokes idle mode. To eliminate the possibility of unexpected outputs at the port pins, the instruction following the one that invokes Idle should not be one that writes to a port pin or to external Data RAM.

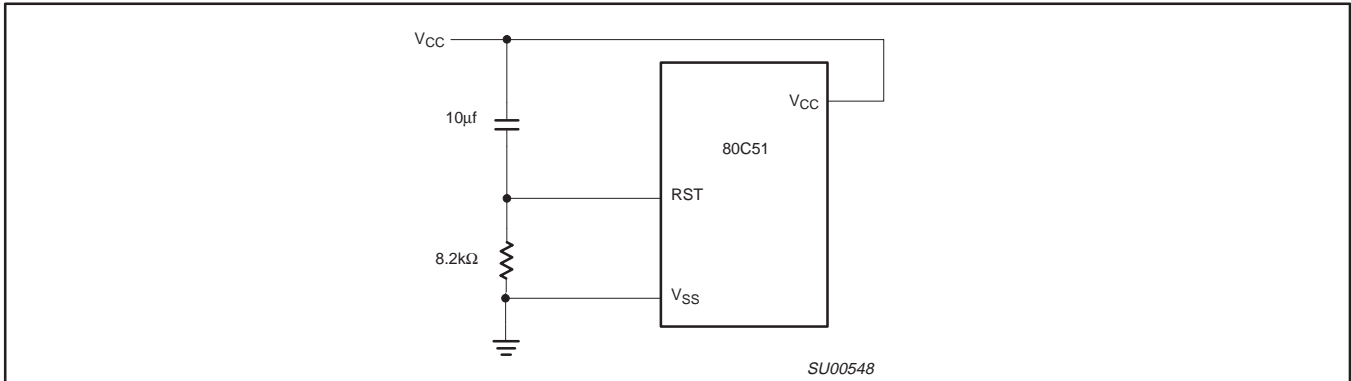

Figure 22. Power-On Reset Circuit

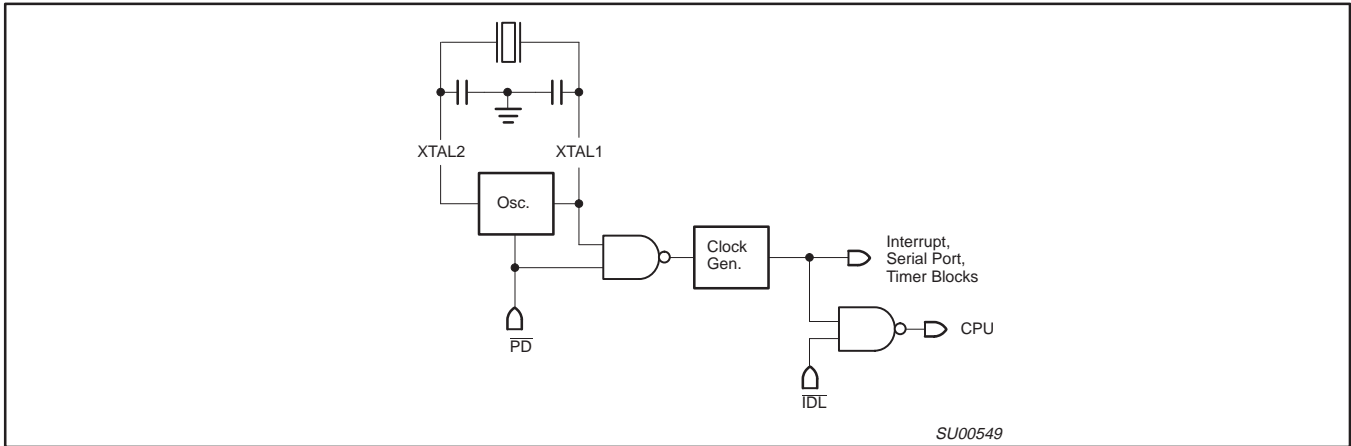

Figure 23. Idle and Power Down Hardware

				MSB					LSB
	SMOD	—	—	—	GF1	GF0	PD	IDL	

BIT	SYMBOL	FUNCTION
PCON.7	SMOD	Double Baud rate bit. When set to a 1 and Timer 1 is used to generate baud rate, and the Serial Port is used in modes 1, 2, or 3.
PCON.6	—	Reserved.
PCON.5	—	Reserved.
PCON.4	—	Reserved.
PCON.3	GF1	General-purpose flag bit.
PCON.2	GF0	General-purpose flag bit.
PCON.1	PD	Power-Down bit. Setting this bit activates power-down operation.
PCON.0	IDL	Idle mode bit. Setting this bit activate idle mode operation.

If 1s are written to PD and IDL at the same time, PD takes precedence. The reset value of PCON is (0XXX0000). In the NMOS devices, the PCON register only contains SMOD. The other four bits are implemented only in the CMOS devices. User software should never write 1s to unimplemented bits, since they may be used in future products.

Figure 24. Power Control (PCON) Register

Power-Down Mode

An instruction that sets PCON.1 causes that to be the last instruction executed before going into the Power Down mode. In the Power Down mode, the on-chip oscillator is stopped. With the clock frozen, all functions are stopped, the contents of the on-chip RAM and Special Function Registers are maintained. The port pins output the values held by their respective SFRs. The ALE and $\overline{\text{PSEN}}$ output are held low.

The only exit from Power Down is a hardware reset. Reset redefines all the SFRs, but does not change the on-chip RAM.

In the Power Down mode of operation, V_{CC} can be reduced to as low as 2V. Care must be taken, however, to ensure that V_{CC} is not reduced before the Power Down mode is invoked, and that V_{CC} is restored to its normal operating level, before the Power Down mode is terminated. The reset that terminates Power Down also frees the oscillator. The reset should not be activated before V_{CC} is restored to its normal operating level, and must be held active long enough to allow the oscillator to restart and stabilize (normally less than 10ms).

ONCE Mode

The ONCE (“on-circuit emulation”) mode facilitates testing and debugging of systems using the device without the device having to be removed from the circuit. The ONCE mode is invoked by:

1. Pull ALE low while the device is in reset and $\overline{\text{PSEN}}$ is high;
2. Hold ALE low as RST is deactivated.

While the device is in the ONCE mode, the Port 0 pins go into a float state, and the other port pins and ALE and $\overline{\text{PSEN}}$ are weakly pulled high. The oscillator circuit remains active. While the device is in this mode, an emulator or test CPU can be used to drive the circuit. Normal operation is restored after a normal reset is applied.

The On-Chip Oscillators

CMOS Versions

The on-chip oscillator circuitry for the 80C51, shown in Figure 25, consists of a single stage linear inverter intended for use as a crystal-controlled, positive reactance oscillator in the same manner as the NMOS parts. However, there are some important differences.

One difference is that the 80C51 is able to turn off its oscillator under software control (by writing a 1 to the PD bit in PCON). Another difference is that, in the 80C51, the internal clocking circuitry is driven by the signal at XTAL1, whereas in the NMOS versions it is by the signal at XTAL2.

The feedback resistor R_f in Figure 25 consists of paralleled n- and p-channel FETs controlled by the PD bit, such that R_f is opened when $\text{PD} = 1$. The diodes D1 and D2, which act as clamps to V_{CC} and V_{SS} , are parasitic to the R_f FETs. The oscillator can be used with the same external components as the NMOS versions, as shown in Figure 26. Typically, $C_1 = C_2 = 30\text{pF}$ when the feedback element is a quartz crystal, and $C_1 = C_2 = 47\text{pF}$ when a ceramic resonator is used.

When a crystal is used at frequencies above 25MHz, C1 and C2 should be in the range of 20pF to 25pF.

To drive the CMOS parts with an external clock source, apply the external clock signal to XTAL1, and leave XTAL2 float, as shown in Figure 27.

The reason for this change from the way the NMOS part is driven can be seen by comparing Figure 25. In the NMOS devices the internal timing circuits are driven by the signal at XTAL2. In the CMOS devices the internal timing circuits are driven by the signal at XTAL1.

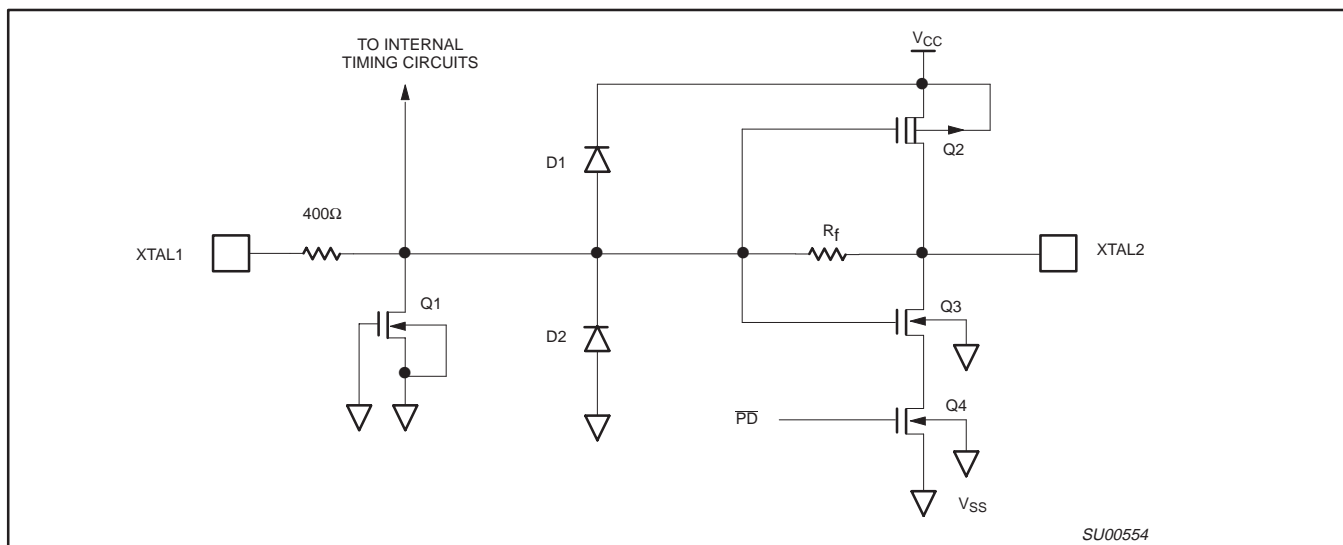

Figure 25. On-Chip Oscillator Circuitry in the CMOS Version of the 80C51 Family

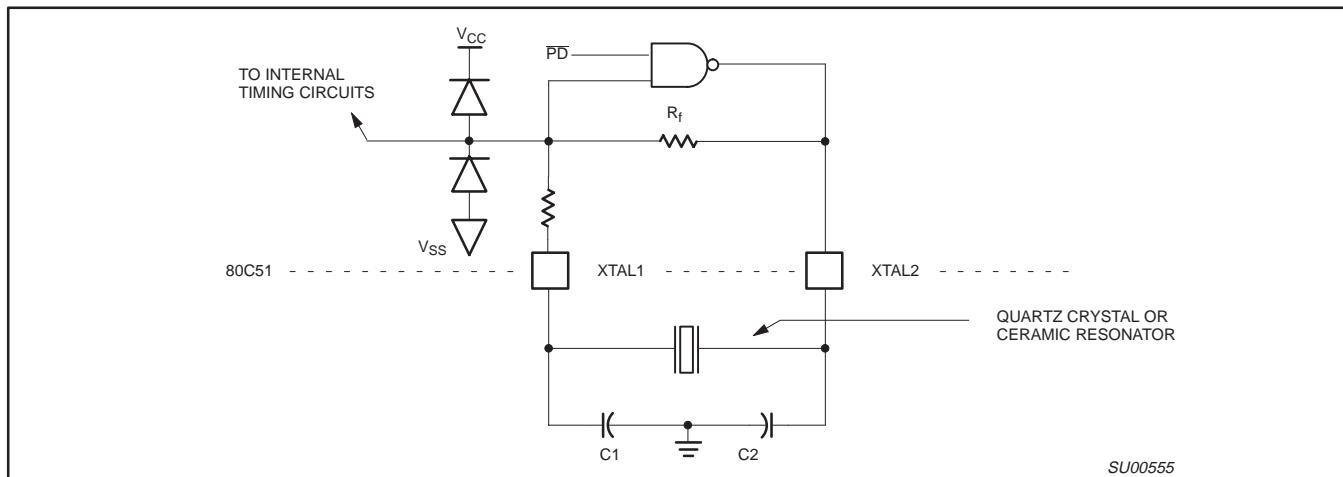

Figure 26. Using the CMOS On-Chip Oscillator

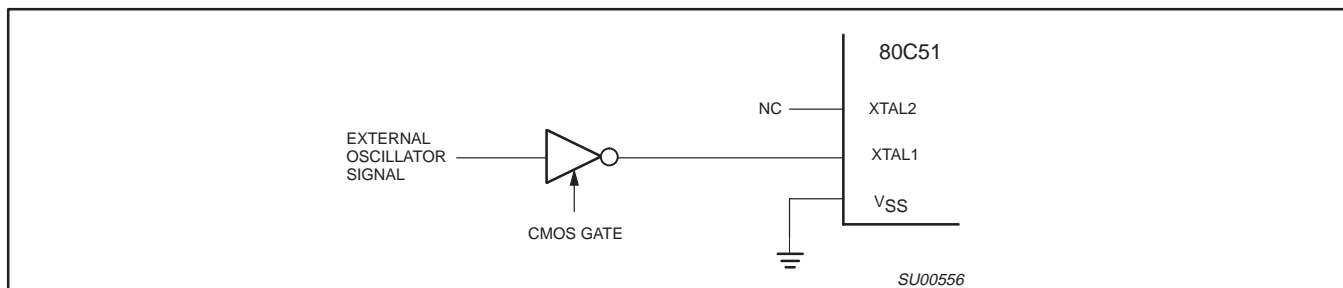

Figure 27. Driving the CMOS Family Parts with an External Clock Source

Internal Timing

Figures 28 through 31 show when the various strobe and port signals are clocked internally. The figures do not show rise and fall times of the signals, nor do they show propagation delays between the XTAL2 signal and events at other pins.

Rise and fall times are dependent on the external loading that each pin must drive. They are often taken to be something in the neighborhood of 10ns, measured between 0.8V and 2.0V.

Propagation delays are different for different pins. For a given pin they vary with pin loading, temperature, VCC, and manufacturing lot. If the XTAL2 waveform is taken as the timing reference, prop delays may vary up to ±200%.

The AC Timings section of the data sheets do not reference any timing to the XTAL2 waveform. Rather, they relate the critical edges of control and input signals to each other. The timings published in the data sheets include the effects of propagation delays under the specified test conditions.

80C51 Pin Descriptions

ALE/PROG: Address Latch Enable output pulse for latching the low byte of the address during accesses to external memory. ALE is emitted at a constant rate of 1/6 of the oscillator frequency, for external timing or clocking purposes, even when there are no accesses to external memory. (However, one ALE pulse is skipped during each access to external Data Memory.) This pin is also the program pulse input (PROG) during EPROM programming.

PSEN: Program Store Enable is the read strobe to external Program Memory. When the device is executing out of external Program

Memory, PSEN is activated twice each machine cycle (except that two PSEN activations are skipped during accesses to external Data Memory). PSEN is not activated when the device is executing out of internal Program Memory.

EA/VPP: When EA is held high the CPU executes out of internal Program Memory (unless the Program Counter exceeds 0FFFH in the 80C51). Holding EA low forces the CPU to execute out of external memory regardless of the Program Counter value. In the 80C31, EA must be externally wired low. In the EPROM devices, this pin also receives the programming supply voltage (VPP) during EPROM programming.

XTAL1: Input to the inverting oscillator amplifier.

XTAL2: Output from the inverting oscillator amplifier.

Port 0: Port 0 is an 8-bit open drain bidirectional port. As an open drain output port, it can sink eight LS TTL loads. Port 0 pins that have 1s written to them float, and in that state will function as high impedance inputs. Port 0 is also the multiplexed low-order address and data bus during accesses to external memory. In this application it uses strong internal pullups when emitting 1s. Port 0 emits code bytes during program verification. In this application, external pullups are required.

Port 1: Port 1 is an 8-bit bidirectional I/O port with internal pullups. Port 1 pins that have 1s written to them are pulled high by the internal pullups, and in that state can be used as inputs. As inputs, port 1 pins that are externally being pulled low will source current because of the internal pullups.

Port 2: Port 2 is an 8-bit bidirectional I/O port with internal pullups. Port 2 emits the high-order address byte during accesses to external memory that use 16-bit addresses. In this application, it uses the strong internal pullups when emitting 1s.

Port 3: Port 3 is an 8-bit bidirectional I/O port with internal pullups. It also serves the functions of various special features of the 80C51 Family as follows:

Port Pin	Alternate Function
P3.0	RxD (serial input port)
P3.1	TxD (serial output port)
P3.2	$\overline{\text{INT0}}$ (external interrupt 0)
P3.3	$\overline{\text{INT1}}$ (external interrupt 1)
P3.4	T0 (timer 0 external input)
P3.5	T1 (timer 1 external input)
P3.6	$\overline{\text{WR}}$ (external data memory write strobe)
P3.7	$\overline{\text{RD}}$ (external data memory read strobe)

V_{CC}: Supply voltage

V_{SS}: Circuit ground potential

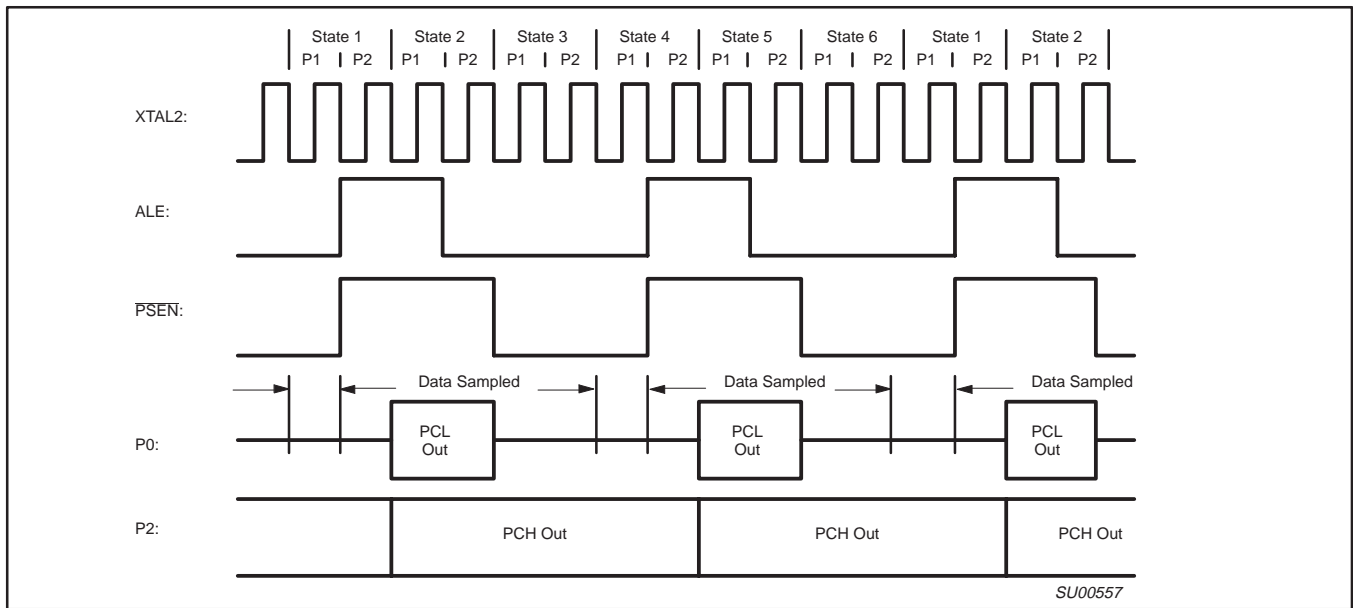

Figure 28. External Program Memory Fetches

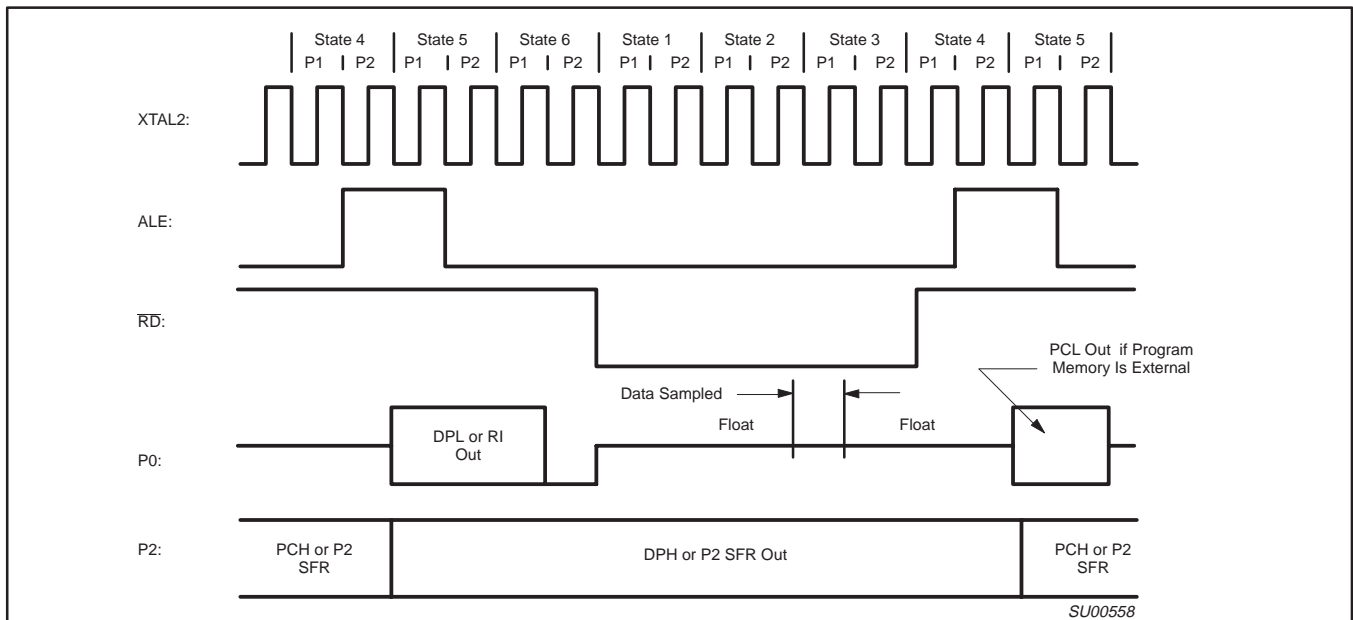

Figure 29. External Data Memory Read Cycle

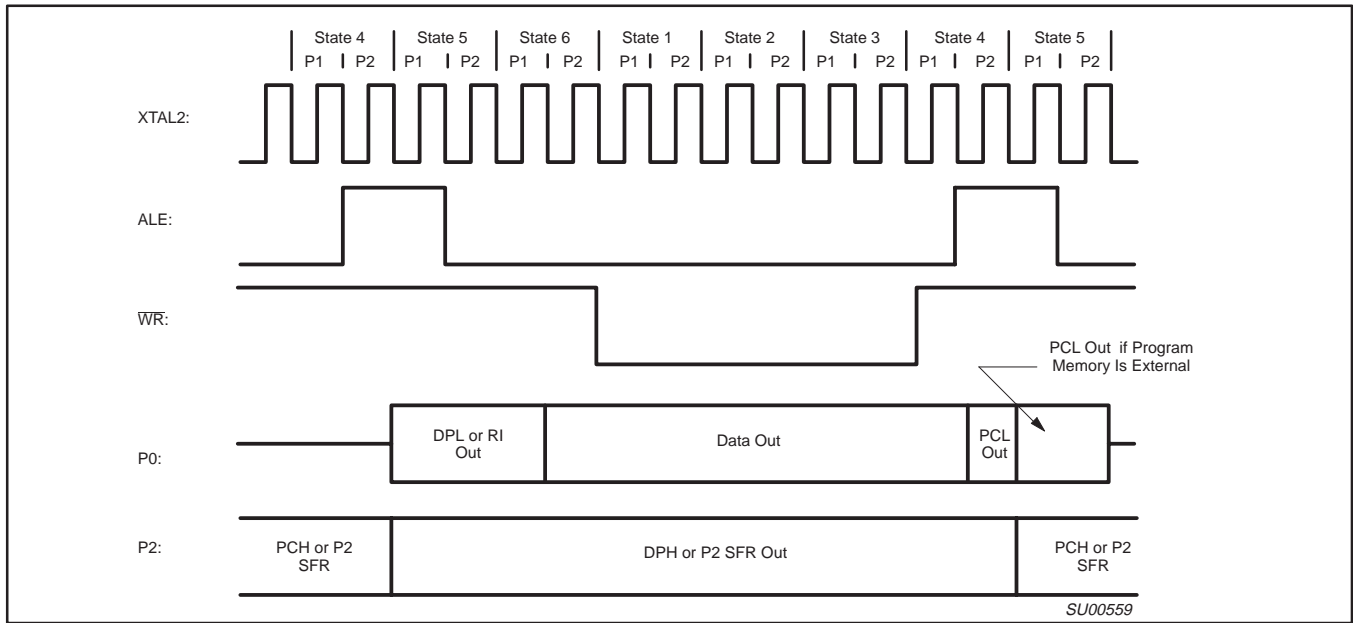

Figure 30. External Data Memory Write Cycle

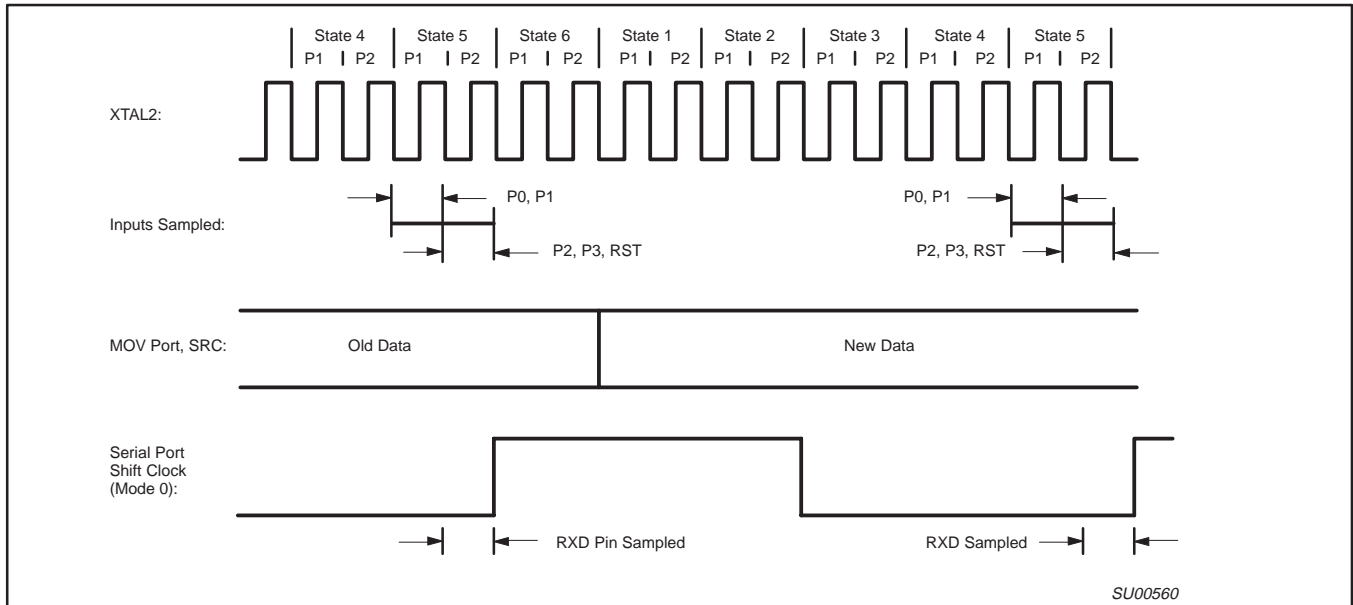

Figure 31. Port Operation